

Hybridization of Islands, Thailand

SITE VISIT REPORT KOH BULON LAE

18/05/2017

ILF Consulting Engineers (Asia) Ltd

88 Dr Gerhard Link Building (B.Grimm), 12th Floor
Krungthepkreetha 99 Rd. (Soi 4)
Huamark, Bangkapi, Bangkok 10240
THAILAND

frank.zimmermann@if.com

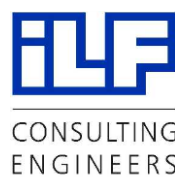

TABLE OF CONTENTS

1	INTRODUCTION	7
2	ISLAND GENERAL OVERVIEW	8
3	SOCIO-ECONOMIC SITUATION	9
	3.1 Demography	9
	3.2 Education	9
	3.3 Occupation, Local Business and Economic Situation	9
	3.4 Typical Appliances	10
	3.5 Community Spirit	10
	3.6 Local Resources	11
4	DIESEL GENERATORS	12
	4.1 Generator #1 (owned by Mrs.Pin)	15
	4.2 Generator #2 (owned by Ms.Yuree/Mr.Mok)	16
	4.3 Generator #3 (owned by Mr.Ali)	16
	4.4 Generator #4 (owned by Ms.Suchanya)	17
	4.5 Generator #12 (owned by Mr.Sompong)	17
	4.6 Generator #18a-b (owned by Chaolae Homestay)	18
5	EXISTING PHOTOVOLTAICS SYSTEMS	19
	5.1 Solar Home Systems	19
	5.2 School PV-Battery System	20
	5.3 BTS PV-Battery System	23
	5.4 Mosque PV-Battery System	26
6	GRIDS	27
	6.1 Cable Anchoring	30
	6.2 Switchgear	31
	6.3 Grid Recommendations	32
7	LOAD PROFILE AND ENERGY CONSUMPTION	33
	7.1 Load Measurements	33

8	ELECTRICITY PRICE STRUCTURE	36
	8.1 Electricity	36
	8.2 Diesel	36
	8.3 Maintenance Costs and Others	37
	8.4 Summary of Costs	37
9	FUTURE ENERGY CONSUMPTION	38
10	POSSIBLE AREAS FOR POWERHOUSE	38
11	POSSIBLE AREAS FOR PV INSTALLATION	38
	11.1 Area 1 to 5: School Area	40
	11.2 Area 6: Replacement of Broken SHARP Modules at BTS1 (DTAC, True)	43
12	WATER STORAGE SYSTEM	43
13	LOGISTICS	45
	13.1 Transportation on the Island	45
	13.2 Availability of Construction Machinery and Manpower Skills	46
	13.3 Possible Laydown Area and Accommodation Facilities during Execution	47
	13.4 Roads	47
	13.5 Pier	48
14	APPENDICES	49

FIGURES

Figure 1: Project location	7
Figure 2: Overview of Koh Bulon Lae (Source: Google Earth taken in 2014)	8
Figure 3: Generator locations observed on the island	12
Figure 4: Generator #1 owned by Mrs. Pin	16
Figure 5: Generator #2 owned by Ms.Yuree/Mr.Mok	16
Figure 6: Generator #3 owned by Mr. Ali	17
Figure 7: Generator #4 owned by Ms.Suchanya	17
Figure 8: Generator #12 owned by Mr.Sompong	18

Figure 9: Generator #18a and #18b owned by Chaolae Homestay	18
Figure 10: Overview of main PV system locations on the island (SHS excluded)	19
Figure 11: Solar Home Systems observed on the island	20
Figure 12: Solar Home System with batteries	20
Figure 13: Overview of PV systems and buildings in the school area	21
Figure 14: Power house including charge controller, inverter and batteries	22
Figure 15: Dirty PV modules observed	22
Figure 16: Rusty mounting structure [left] and combiner box [right]	22
Figure 17: PV-battery system supplying public health centre	23
Figure 18: PV-battery system supplying the building for teacher resting	23
Figure 19: Overview of BTS1 (True,DTAC), BTS2 (AIS) and PV systems	24
Figure 20: Simple diagram of PV systems supplying BTS1 and BTS2	24
Figure 21: PV system supplying the electricity for the BTS1 (PV1) and rusty components	25
Figure 22: PV system supplying the electricity for the BTS1 (PV2)	25
Figure 23: Poor ventilation for PV modules [left] and rusty flexible conduit [right]	25
Figure 24: Battery cabinets	26
Figure 25: PV rooftop and batteries supplying BTS2	26
Figure 26: PV system located at mosque	27
Figure 27: Existing grid transmission lines connected with BTS	28
Figure 28: Grid line from Generator 6 to BTS1	29
Figure 29: Grid line from school PV system to BTS2	29
Figure 30: Grid line along pathway to BTS2	30
Figure 31: Wooden stick as a pole and tree connection	31
Figure 32: Concrete pole at Similan Resort [left] and steel poles towards BTS2 [right]	31
Figure 33: Island overview of proposed transmission line route.	32
Figure 34: Load measurement LAE 1 at Generator #18	35
Figure 35: Possible area to install new powerhouse and PV	38
Figure 36: Overview of possible areas to install new PV systems within the school area	40
Figure 37: Overview of the new public health centre area	41

Figure 38: Overview of existing PV at school with area boundaries	41
Figure 39: Rooftop sheet and structure of the public health centre	42
Figure 40: Rooftop sheet and structure of classroom building	42
Figure 41: Rooftop of school's main building with approximate sizing	43
Figure 42: Twelve broken SHARP modules at BTS1	43
Figure 43: Large pond with water pumping	44
Figure 44: Deep well underground water source	44
Figure 45: private storage tank collecting raining water	45
Figure 46: Small tractor for transportation on the island	45
Figure 47: Motorbike with sidecar for transportation on the island [left]; diesel transport to the island [right]	46
Figure 48: Panka Noi Bay at low tide	46
Figure 49: Manpower observed on the island	47
Figure 50: Typical concrete road on Koh Bulon Lae (width approx. 2 m)	47
Figure 51: Typical dirt road heading to Manga Bay	48
Figure 52: Floating pier at Mango Bay	48

TABLES

Table 1: The income of households and resorts for low and high season	9
Table 2: Generator information according to Figure 3	13
Table 3: Cable types observed on the island	27
Table 4: Pole types	30
Table 5: Proposed setup of the new grid	33
Table 6: Load measurement	33
Table 7: Overview of Generator #18	34
Table 8: Overview of Generator #1	35
Table 9: Actual Generation Costs for Generator 1	37
Table 10: Cost sharing structure for Generator 1	37
Table 11: Profit-and-Loss for Generator 1	Error! Bookmark not defined.

Table 12: Data summary of pre-selected and reviewed PV areas	39
--	----

APPENDICES

Appendix 1: List of the generators observed during the site visit with the GPS location	49
Appendix 2: Generator information observed during the site visit	50
Appendix 3: Summary of PV System	52
Appendix 4: Site Survey Overview	54

1 INTRODUCTION

The Deutsche Gesellschaft für Internationale Zusammenarbeit (GIZ) is assessing a project for the hybridization of two Thai islands in the Andaman Sea. The target of this study is to select two out of three islands for the design and development of a technical and financial feasible hybrid system using a combination of photovoltaics (PV), batteries and diesel generators to supply large parts of the islands with one power generation system (the Project).

Koh Bulon Lae is one out of three islands for the Project. The island is located in the Andaman Sea in the province of Satun, approx. 80 km away from the Malaysian border. The current power generation relies heavily on large diesel generators, which supply small grids up to 10 houses and resorts up to 40 bungalows, or smaller units powering single households.

A site visit was conducted from 27th to 28th February 2017 to analyse the load of the island and the condition of the existing grids, to identify suitable areas for the installation of PV, batteries and a powerhouse, to determine possible long-term impacts and changes of the future energy demand and to investigate the socio – economic situation of the island.



Figure 1: Project location

2 ISLAND GENERAL OVERVIEW

The island of Bulon Lae is located in the Andaman Sea in the province of Satun approx. 22 km from the Pak Bara pier. The current power generation relies heavily on diesel generators, which supply small grids with up to 10 houses. Resorts connect up to 30 Bungalows including A/C in some cases.

170 residents live permanently on Koh Bulon Lae in 79 households, furthermore there are 11 resorts on the islands. The economy of the island relies mainly on tourism from December till March with up to 4,000-5,000 tourists per year. Besides tourism the economy of Koh Bulon Lae depends on rubber plantation, coconut plantation and fishery. Main buildings of the island are the health centre, school, mosque and the Base Transceiver Stations (BTS). Koh Bulon Lae has no permanent pier and the bays of the island allow boat access only during high tide. It has to be noted, that Koh Bulon Lae is currently under Mu Koh Phetra National Park. A drainage system for the whole island has not been observed.

The weather condition on the island is sunny, rainy and windy. The rainy season lasts from May until October, which is also low tourist season. During the rainy season, it may happen that the boats cannot go out for up to 3-4 days. A tsunami hit the island in the past.

Two Base Transceiver Stations (BTS) were built on the island owned by DTAC, AIS and True. The mobile signal and internet data is therefore good.

Figure 2 shows the island with some important places and uninhibited area.

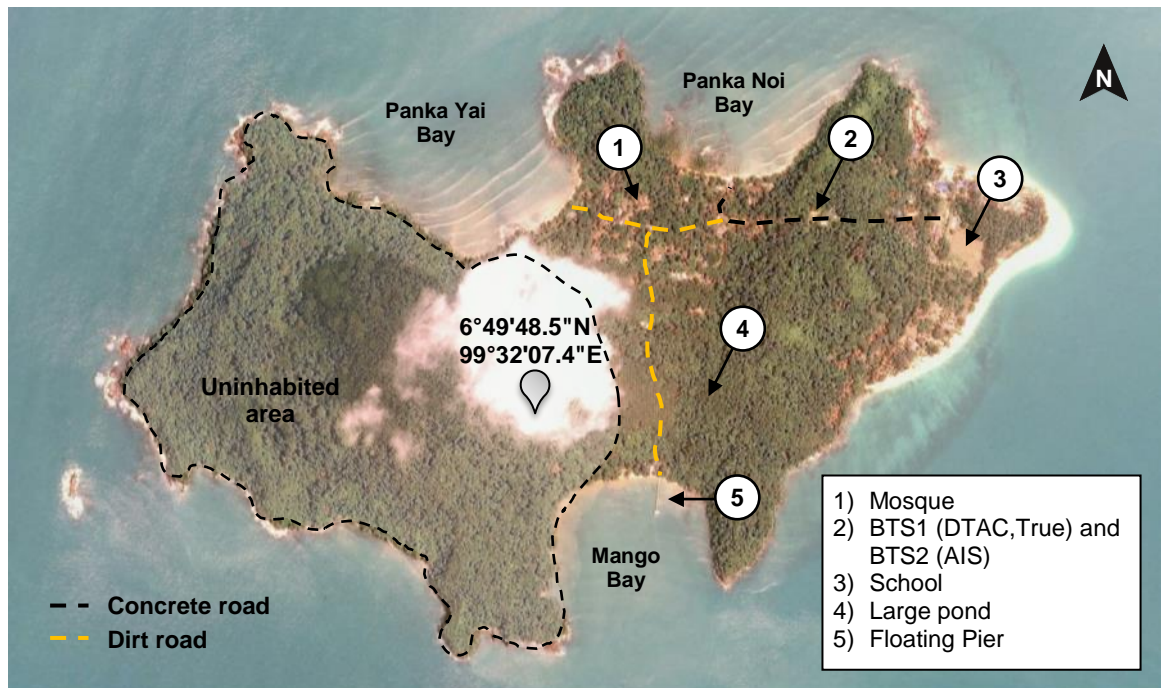

Figure 2: Overview of Koh Bulon Lae (Source: Google Earth taken in 2014)

3 SOCIO-ECONOMIC SITUATION

3.1 Demography

According to Chaipattana Development report, the number of households in 2012 was 68. The number of population and households in 2016 are 170 and 79 respectively. 11 additional households were built over the last 4 years.

The island has a well-established tourism sector. Approximately 4,000-5,000 tourists are visiting the island every year. Therefore, numerous bungalows and resorts can be observed. The high touristic season is from November until February. The low season is March until October with almost no tourists arriving from April to September. As a result, the electricity consumption of the resorts during the high season is higher compared to the other months. Furthermore, there are approx. 20-30 seasonal workers living on the island during high season.

3.2 Education

The Ban Bulon School on the island provides education to local children until 9th grade (“Matayom 3”). Based on an interview with the school staff, there are currently 35 students.

The school receives a budget of around THB 100,000 – 150,000 per semester from the central government for its operation (teaching materials, office supplies, etc.) The lunch meals for all school children are subsidised by the SAO with THB 20 per student per day.

3.3 Occupation, Local Business and Economic Situation

The average income on the island is widely spread depending on the type of occupation and seasonality. An overview is given in Table 1.

Table 1: The income structure of households and resorts for low and high season

Type of customers	Low season (Mar-Oct)		High season (Nov-Feb)	
	Ranging (THB/month)	Average (THB/month)	Ranging (THB/month)	Average (THB/month)
Households	2,000-30,000	9,500 with	2,000-70,000	32,000 with
Resort Owners	-	-	30,000 (3 bungalows) - 3,000,000 (30 rooms)	700,000

The main income source is fishery, boat services, tourism sector and services, grocery, and gastronomy. A combination of accommodation facilities, gastronomy and boat

services for those involved in the tourism sector is common. These people often rely on the income generated during high season all year around.

3.4 Typical Appliances

The collected data shows that typical household appliances are lighting, TV, mobile phone charger and fan. Some households have a washing machine, radio, rice cooker, blender and water pumps. Normal operation hours are from 18:00 – 23:00 but may vary depending on the needs of the households connected to the generator.

Besides the residential buildings, there are several public buildings such as the health centre, school (08:00 – 13:00) and mosque. These types of buildings are mostly equipped with common electrical devices such as lighting, TV, fan, speaker and computer. The mosque has additional outdoor speakers to call the prayers (5 times a day; 3 times during the day and 2 times after sunset) and an indoor speaker system for the praying. The usual time for each call for prayer together with the praying itself is usually not exceeding 30 minutes.

The standard accommodation facilities for the tourists (bungalows or rooms) are equipped with 2-3 lights and 1 fan. Some also include a TV and one even offers air condition (Bulone Resort). The resorts and hotels are mostly combined with restaurants equipped with refrigerators.

During the site assessment, the team found 3 ice machines in one resort currently not operating because of the high electricity generating cost on the island and limited supply. Due to the high ice demand and expenditures on the island, the reactivation of these machines should be considered in the load while designing the potential RE diesel hybrid grid system.

More details as well as the respective operation hours of the appliances can be found in the survey evaluation table.

3.5 Community Spirit

The community is quite divers and mostly split into family/relative groups. The community spirit is compared to other islands difficult to assess. Some interviewees stated that people are not keen on contributing to community projects (both in terms of labor and financial contribution). Most of the resorts/households focus on their own operation/business (e.g. procurement of their own generator, building up their own grids, building up their own water well, etc.). However, these are individual opinions and might not reflect the actual situation.

3.6 Local Resources

Currently a lot of villagers are operating and maintaining diesel generators, which means they have a certain technical know-how the Project can build upon. Most houses are also constructed by the villagers themselves, which may promise construction skills useful for the Project.

4 DIESEL GENERATORS

On Koh Bulon Lae, basically every resort has at least one generator to power its bungalows and restaurant. Several households are connected to smaller grid infrastructures. An overview of the grid supplying generators and the related grids is given in the following chapters. It has to be noted, that in almost all cases either the motor or the generator or both machines have no nameplate, therefore the power could be assessed only for some of the machines, if at all. In the cases where more than one generator is used, usually one of the generators provides power for the evening, the other one for the night. Figure 3 shows all generators observed on the island during the site visit.



Figure 3: Generator locations observed on the island

Table 2 summarizes the information of all generators.

Table 2: Generator information according to Figure 3

No	Generator	Owner / Operator	Power	No. and type of connected loads
1	Generator #1	Mrs. Pin	- 4.8kW rated (Motor)	- 4 residential houses - 1 restaurant - 1 water pump (370 W)
2	Generator #2	Ms.Yuree/ Mr.Mok	- 3kW (AC Generator)	- 3 residential houses - 1 bar - 1 restaurant
3	Generator #3	Mr. Ali	- 5kW (AC Generator)	- 2 residential houses - 1 restaurant - Power tools (drills, moulding cutter for coconuts, circular saw, etc.)
4	Generator #4	Ms. Suchanya	- 2.2kW (AC Generator)	- 1 restaurant - 1 water pump
5	Generator #5	Mr. Anucha	- 8.46kW max (Motor)	- 2 residential houses
6	Generator #6	Mr. Biron	- Broken	- 2 residential houses
7	Generator #7	Mr. Puttama	- Unknown	- 1 residential house
8	Generator #8	Mr. Dara	- 4.8kW	- Movable generator for use of construction and wood making tools
9	Generator #9	Mr. Dara	- 7.72kW max (Motor)	- 3 residential houses
10	Generator #10	Mr. Chai-Rama Harnthale	- Unknown	- 3 residential houses
11	Generator #11	Mr. Nawin Harnthale	- 650W rated (AC Generator)	- Secretly use for 1 of 3 houses (Generator #10)
12	Generator #12	Mr. Sompong	- 4.8kW rated (Motor)	- 2 restaurants
13	Generator #13	Bulon Viewpoint Resort	- 20kW (AC Generator) - 50kW (AC Generator)	- Bulon Viewpoint Resort (25 rooms) - BTS True, DTAC - Generators currently not in use

No	Generator	Owner / Operator	Power	No. and type of connected loads
14	Generator #14	Mr. Raman	- 5.5kW max (Motor)	- 2 residential houses
15	Generator #15	Jungle Hut Resort	- Unknown	- Jungle Hut Resort (14 bungalows, 1 residential house, 1 restaurant)
16	Generator #16	Community	- Unknown	- Community water pump
17	Generator #17	Jungle Hut Resort	- Unknown	- Jungle Hut Resort's water pump
18	Generator #18a-b	Chaolae Homestay	- 8.46kW max (Motor) - 8.94kW max (Motor)	- 8 residential houses - 8 bungalows - 1 restaurant
19	Generator #19a-b	Jiab Resort/ Similaa Resort	- 5.5kW max (Motor) - 20kW (AC Generator)	- 2 residential houses - 12 bungalows (including 2 currently under construction) - 1 restaurant - 1 shop
20	Generator #20	Coconut Bar	- 3kW rated	- bar
21	Generator #21	Mango Bar	- Unknown	- bar
22	Generator #22	Baan Suleida Resort	- Unknown	- 7 bungalows
23	Generator #23	Sawleena Resort/shop & Rud's Resort/shop	- Unknown	- 2 shops - 2 Rud's Resort Bungalows - 5 Sawleena Resort Bungalows - 1 residential house
24	Generator #24a-d	Marina Resort	- 8.46 kW rated (Motor) with 15kW (AC Generator) - 5kW (AC Generator) - 3kW for restaurant - 5kW for backup purpose	- 15 bungalows - 1 restaurant - 1 shop

No	Generator	Owner / Operator	Power	No. and type of connected loads
25	Generator #25a-c	Bulone Resort	- 130kW - 60kW - 20kW	- 30 bungalows (with AC) - 1 restaurant
26	Generator #26a-b	Bulonhill Resort	- 5kW - Unknown	- 8 bungalows - 1 restaurant
27	Generator #27a-b	Pansand Resort	- 20kW (AC Generator) - 20kW (AC Generator)	- 11 bungalows for staff - 24 bungalows - 1 restaurant
28	Generator #28	Pangka Bay Resort	- 8.7kW max (Motor)	- 20 bungalows - 1 restaurant
29	Generator #29a-b	BTS 1 (True, DTAC)	- 26.4kW (AC Generator) - 27kW	- BTS tower 1, for True and DTAC
30	Generator #30a-b	BTS 2 (AIS)	- 22kW (AC Generator) - 18kW (AC Generator)	- BTS tower 2, for AIS
31	Generator #33a-b	Mosque	- 8.5kW rated (Motor) with 15kW (AC Generator) - 7.7 rated (Motor)	- Mosque - 1 residential house
32	Generator #34	Seasonal worker	- Unknown	- 1 residential house for seasonal worker

Due to the time constraint during the site visit, only 6 generators were evaluated which can be considered to be representative to design the hybrid system at a later stage. The detailed specifications of each generator are listed in Appendix 2.

4.1 Generator #1 (owned by Mrs. Pin)

This generator is located near Aao Panka Noi, next to Thanee's house. The engine brand is YANMAR TF 75-LM. The generator nameplate was not readable. There is a power house with a metal roof sheet and the generator is placed on a concrete slab floor. Diesel consumption is reported to be around 5 litres per night. The generator supplies power to 4 houses and 1 restaurant. It is operated by Mrs. Pin and connected to their small grid. The grid was set up more than five years ago and operated since then.



Figure 4: Generator #1 owned by Mrs. Pin

4.2 Generator #2 (owned by Ms. Yuree/Mr.Mok)

This generator is located near Aao Panka Noi, next to the shore. The engine brand is YANMAR TF 120–DI. There is a powerhouse with a metal roof sheet and the generator stands on wooden logs on a concrete slab floor. Diesel consumption is around 5 litres per night. The generator supplies power to two houses, one shop and one bar. It is operated by Mr. Mok and connected to a small grid. The grid was set up around five years ago and operated since then.



Figure 5: Generator #2 owned by Ms.Yuree/Mr.Mok

4.3 Generator #3 (owned by Mr. Ali)

This generator is located in Bulon-Lae Village. The engine brand is YANMAR. There is a powerhouse with a corrugated sheet roof and the generator stands on a metal trolley on concrete slab floor. Diesel consumption is around 3 litres per night. The generator supplies power to three houses via a small grid which was set up around 10 years ago. The generator is operated by Mr. Ali.



Figure 6: Generator #3 owned by Mr. Ali

4.4 Generator #4 (owned by Ms. Suchanya)

This generator is located at the intersection between Aao Panka Noi and Aao Panka Yai. The engine brand is BERALA TP25000A. There is no powerhouse and the generator is positioned under trees. Diesel consumption is around 4-5 litres per night. The generator supplies power to 1 restaurant and is operated by Ms. Suchanya. The grid was set up around five years ago.



Figure 7: Generator #4 owned by Ms. Suchanya

4.5 Generator #12 (owned by Mr. Sompong)

This generator is located near Aao Panka Noi, next to Generator #1 of Mrs. Pin. The engine brand is Yanmar TF 75-HM. There is a small powerhouse with a metal roof and the generator stands on a metal trolley on concrete slab floor. Diesel consumption is around 10 litres per night. The generator supplies power to 2 restaurants. It is operated by Mr. Sompong and connected to their small grid. The grid was set up around three years ago.



Figure 8: Generator #12 owned by Mr.Sompong

4.6 Generator #18a-b (owned by Chaolae Homestay)

There are two generators which are Yanmar TF120DI-H (8.8 kW max output) and Yanmar TF115-LM (8.46 kW max output) as shown in Figure 9 from left to right respectively. These generators were installed inside a small powerhouse with a metal roof sheet. Poor ventilation inside the powerhouse has been observed. The generators supply the electricity to 8 households, 8 bungalows and 1 restaurant. The generators are operated and maintained by Mr. Rit. There is a switch to choose which generator shall be connected to the grid, both generators cannot be connected with the grid at the same time. Diesel consumption is around 13-17 litre/night during high season and 6-9 litre/night during low season.

The load measurement device was installed at these generators as described in detail in Chapter 7.1.



Figure 9: Generator #18a and #18b owned by Chaolae Homestay

5 EXISTING PHOTOVOLTAICS SYSTEMS

Figure 10 shows an overview of the larger PV systems on the island, not including the Solar Home Systems (SHS). The detailed specifications of each system are listed in Appendix 3.

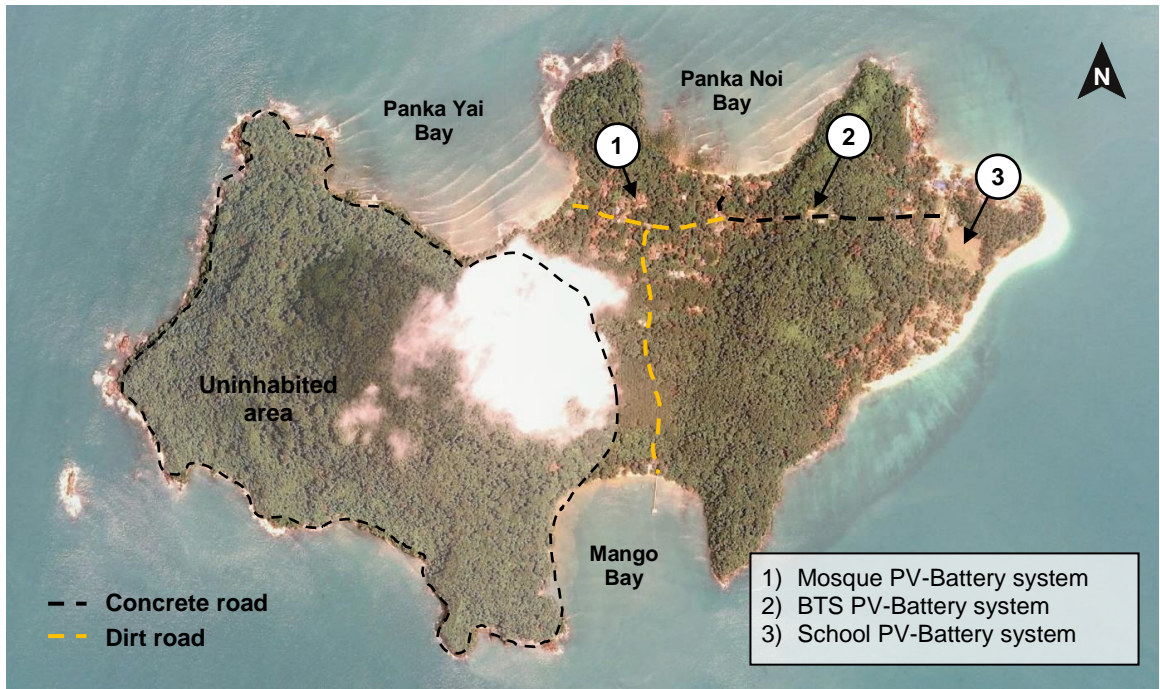

Figure 10: Overview of main PV system locations on the island (SHS excluded)

5.1 Solar Home Systems

Figure 11 shows the SHS available on the island. There are around 100 SHS provided by PEA in the past, while only approx. 20 modules are still working. The modules are 130 W_p of Northern Sunshine. There are different setups in each household with a SHS: various inclinations, various facing directions, installation types (rooftop setup, ground-mounted), inverters, etc. Some households have SHS with battery storage as shown in Figure 12. Additionally, there were some private initiatives to install solar panels; however, systems are often broken or shaded.



Figure 11: Solar Home Systems observed on the island



Figure 12: Solar Home System with batteries

5.2 School PV-Battery System

Figure 13 shows the overview of PV systems and buildings in the school area.

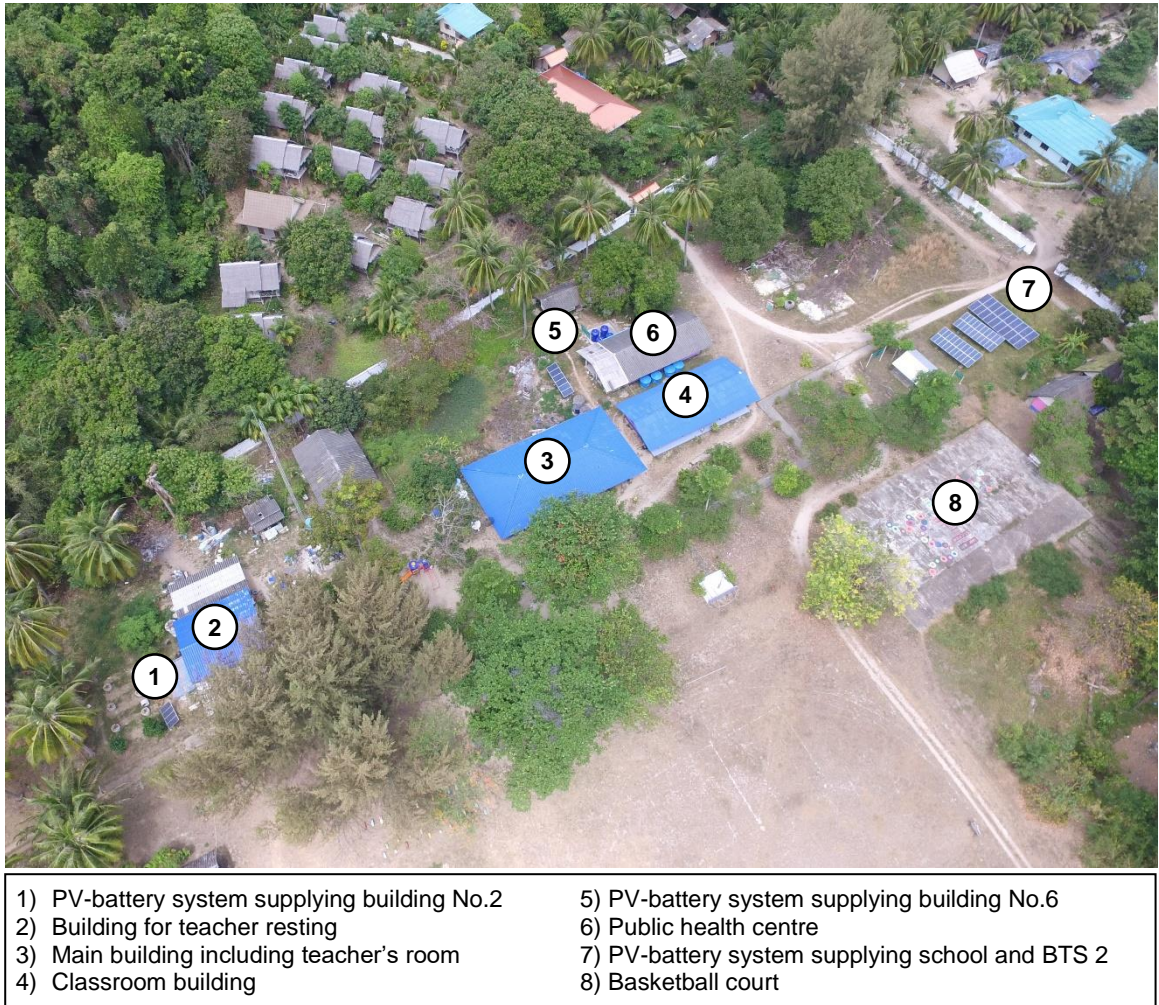

Figure 13: Overview of PV systems and buildings in the school area

The PV-battery system No.7 in Figure 13 is supplying the school and BTS2 with electricity. There are two different PV modules installed:

1. 40 modules of 130 W_p Solartron SP130, totaling 5.2 kW_p, mounted in the two front rows and connected via charge controller to 24 batteries of Torch GGM (OPzS) 1000 (specification of battery: nominal voltage 2 V, capacity 1000 Ah). The system is connected to an inverter supplying the electricity for the school.
2. 20 modules of 300 W_p Q Cells Q.Pro L 300, totaling 6.0 kW_p, installed in the last row and connected with 24 batteries of Varta model 7 OPzS 490 (specification of battery: nominal voltage 2 V, capacity 490 Ah). The system is connected to an inverter supplying the electricity for BTS2.

All solar modules are facing into Southern direction with an inclination of 15°. The system is affected by shading from the trees in the East. Dirty PV modules are observed as shown in Figure 15 and the grass is mowed irregularly.



Figure 14: Power house including charge controller, inverter and batteries



Figure 15: Dirty PV modules observed

The mounting structure and combiner box are rusty as shown in Figure 16. It can be presumed that the installed material is not corrosion resistant.



Figure 16: Rusty mounting structure [left] and combiner box [right]

Figure 17 shows the PV-battery system supplying the electricity for the public health centre. There are 6 PV modules which are 250 W_p of Schutten STP6-250/60, totalling 1.5 kW_p. The system is facing South with an inclination of approx. 15°. However, the

nurse mentioned that the electricity supply is not enough. The medical centre has high wattage appliances oxygen concentrator, rice cooker and electric kettle. The electric kettle cannot be used as the inverter will cut out.



Figure 17: PV-battery system supplying public health centre

Another PV-battery system is supplying the electricity for the teacher's resting building as shown in Figure 18. The modules are 120 W_p Solartron SP120. The system is facing South. The inverter is currently out of order, the reason is said to be lightning strikes, while PV modules, charge controller and batteries are still working.



Figure 18: PV-battery system supplying the building for teacher resting

5.3 BTS PV-Battery System

Figure 19 shows the drone picture of BTS1 (DTAC, True) and BTS2 (AIS) including PV systems supplying the electricity for both BTS.



Figure 19: Overview of BTS1 (True,DTAC), BTS2 (AIS) and PV systems

There are four different PV module types connected to BTS1 and two systems connected to BTS2 as described in Figure 20. The total PV capacity of PV1, PV2 and PV rooftop is 6 kW_p, 11.34 kW_p and 2.34 kW_p respectively.

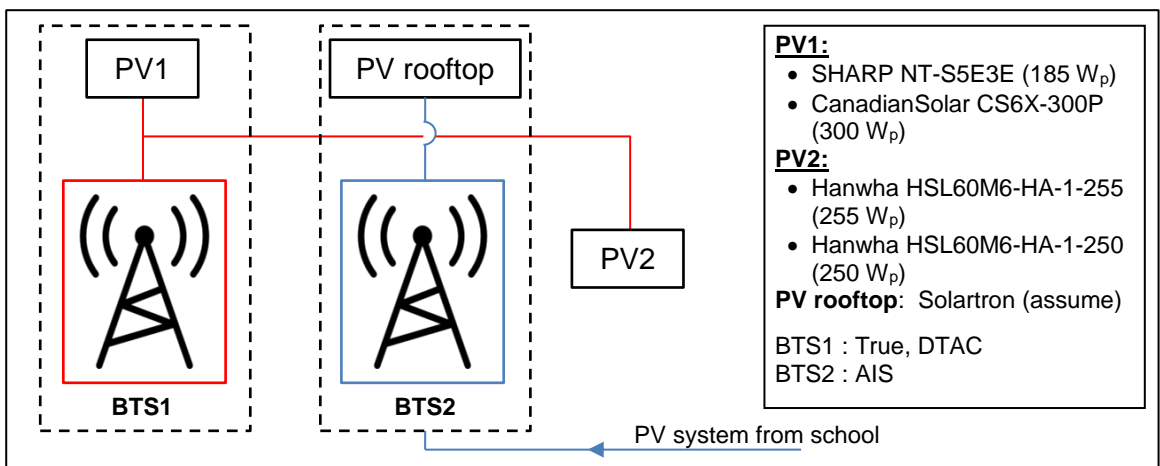

Figure 20: Simple diagram of PV systems supplying BTS1 and BTS2

The PV system (PV1) located within BTS1 area comprises of 12 modules of 185 W_p SHARP NT-S5E3E and 20 modules of 300 W_p CanadianSolar CS6X-300P as shown in Figure 21. The SHARP modules are currently not working. In the combiner box, some

rusty components were observed. Both modules are facing towards South-West direction with an inclination of 15°.



Figure 21: PV system supplying the electricity for the BTS1 (PV1) and rusty components

Figure 22 shows the PV system located next to BTS2. The system comprises of 27 modules of 250 W_p Hanwha HSL60M6-HA-1-250 and 18 modules of 255 W_p Hanwha HSL60M6-HA-1-255., totalling 11.31 kW_p. The modules are facing South-West. Poor ventilation for PV modules and rusty flexible conduit were observed as shown in Figure 23. The system is also connected to batteries, shown in Figure 24.



Figure 22: PV system supplying the electricity for the BTS1 (PV2)



Figure 23: Poor ventilation for PV modules [left] and rusty flexible conduit [right]



Figure 24: Battery cabinets

There is a PV rooftop installation supplying electricity to BTS2 as shown in Figure 25. The modules were not accessible. However, the modules might be the same as the system at the school (130 W_p Solartron SP130). The total capacity of the 18 PV modules is therefore estimated with 2.34 kW_p. The system is also connected to the batteries.



Figure 25: PV rooftop and batteries supplying BTS2

5.4 Mosque PV-Battery System

Figure 26 shows the PV-battery system supplying electricity for Bulon Lae mosque. There are five PV modules which are 120 W_p Solartron SP120 connected to 3 batteries. The modules are shaded due to surrounding trees.



Figure 26: PV system located at mosque

6 GRIDS

As shown in Figure 3, each generator on Koh Bulon Lae feeds an independent grid, which supplies the loads. There are no interconnections between the grids. Stand-alone residential grids, such as the grids of Generator #1, #2, #3, #4, #12, etc., mainly use the 2x1.5 mm² VAF cable.

According to the Thai standard, VAF cables should not be exposed to sunlight directly to avoid embrittle, it should be used indoor only.

The cable specifications on the island of different grids are listed in Table 3.

Table 3: Cable types observed on the island

Cross-section [mm ²]	Spec.	Standard year	Manufacturer	Usage
10	THW – A	2541	Bangkok Cable	Existing grid 2 (PV at School to BTS 2)
35	THW – A	2541	Bangkok Cable	Similan Resort
50	THW – A	2541	Bangkok Cable	Existing grid 1 (Generator #13 to BTS 1)
2x1.5 mm ²	VAF	2541	Bangkok Cable	Typical house connection
2x25 mm ²	NYN	2531	Bangkok Cable	Typical PV Solar connection

In addition to the stand-alone residential grids, two existing major grids have been installed on the island. Both of the grids are connected to one of the BTS towers as shown in Figure 27. Details of the grids are described below.

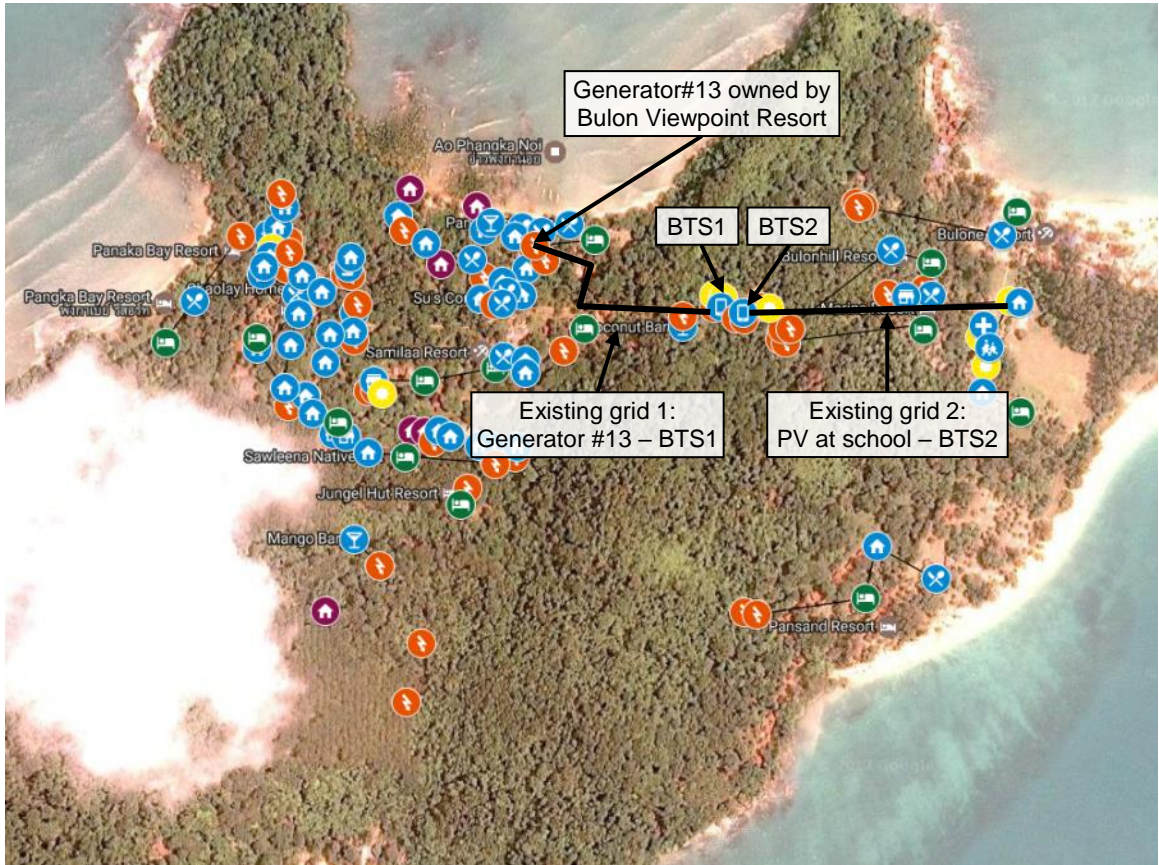

Figure 27: Existing grid transmission lines connected with BTS

1st existing larger grid (Generator #13 / BTS 1):

As seen in Figure 27 **Error! Reference source not found.**, a grid is connecting Generator #13 and the BTS1 tower. The generator is owned by Bulon Viewpoint Resort (specification of the generator: 3 phases 20 kW, 400 V, 50 Hz, year 2001). The generator is used to supply the electricity for the BTS1 but since the BTS1 upgraded to an internal Hybrid system, the grid is not in-use anymore. The grid is a single-phase system with the cable specification of 50 sq.mm THW-A, Bangkok Cable and still in good condition.

As shown in Figure 28, the poles along the road are wooden or steel type poles with a height of around 2 meters. In some cases, the conductors are fixed to trees. The ownership (BTS operator or private) of the cable could not be clarified. However, any future usage of the grid shall be discussed with the owner. Nevertheless, some poles require replacement or improvement since they are not durable or not high enough.



Figure 28: Grid line from Generator 6 to BTS1

2nd existing larger grid (School's PV system / BTS 2):

The second larger grid is the connection between the School's PV system and the BTS2 tower. The grid is a single-phase system as shown in Figure 29 and Figure 30. The system is still in operation and the PV system at the school supplies power to the BTS2. Details of the PV system are described in Chapter 5.2. The conductor is a 10 sq.mm THW-A, Bangkok Cable in good condition. The steel type poles are in good conditions; however, they are less than 2 m high. The poles might be replaced or rectified. The final conductor size shall be confirmed and a replacement might be necessary. It needs to be clarified if the existing grid could be used as a public grid.



Figure 29: Grid line from school PV system to BTS2



Figure 30: Grid line along pathway to BTS2

6.1 Cable Anchoring

The different grids on the Island can be clustered and categorized according to the type of transmission as listed in Table 4.

Table 4: Pole types

Type	Used frequency
Tree	Often
House to house	Often
Wooden poles	Seldom
Steel poles	Seldom
Concrete poles	Only Similan Resort internal grid
Underground	Only TOT PV System to school

The cables are usually connected to the poles in a height between 2 m – 2.5 m above the ground. This result in cables hanging down between poles in a height that people can touch them by accident.



Figure 31: Wooden stick as a pole and tree connection



Figure 32: Concrete pole at Similan Resort [left] and steel poles towards BTS2 [right]

6.2 Switchgear

All existing grids are equipped with manual switches to disconnect the generators from the load. These switches are used to protect the load from starting current of the generator. Some of the switches are in a bad condition with open parts, which may result in very dangerous electric shocks, if touched in operation.

In some cases, fuses are installed to protect the load from overcurrent. However, all installations are missing the residual current devices (RCD) to protect people from overcurrent and surge arresters to protect the loads in case of a lightning strike. A new

system on Koh Bulon Lae shall include these safety devices to protect people and connected loads.

6.3 Grid Recommendations

In case of a centralized system on Koh Bulon Lae, the system should come along with a new grid.

Figure 33 shows the proposed new grid transmission route on the island. The new transmission grid fed by a PV-hybrid system possibly located at the school (see Chapter 11.1) is shown as black line with a length of app. 1.6 km. It can be designed as a single phase or as a three-phase system. To establish an integrated system (hotels and households), it must be clarified with each resort owner whether they are willing to connect or not.

The recommended type of pole for the new transmission line is concrete or wood.

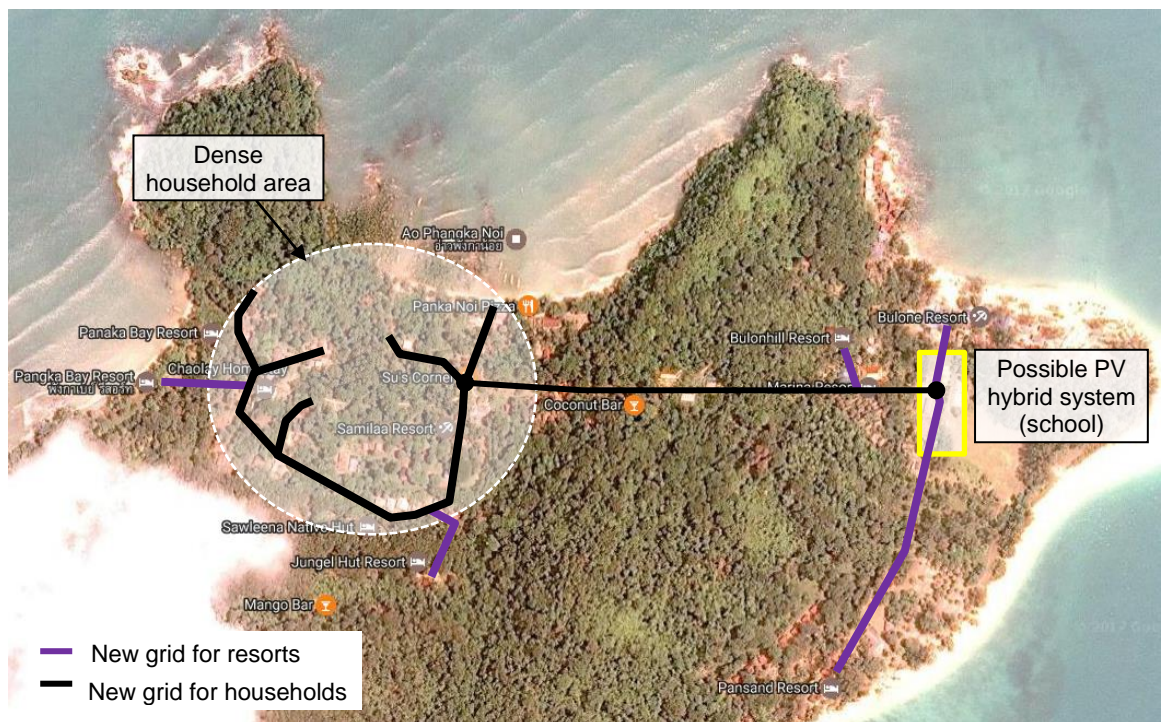

Figure 33: Island overview of proposed transmission line route.

The following table is giving the specifications for the new transmission line.

Table 5: Proposed setup of the new grid

Parameter	Value
Cables	
Total cable length [m]	Black line: ~1.6 km (for households) Purple line: ~1.3 km (for resorts)
Cable cross section [mm ²]	To be specified and calculated
Insulation type	XLPE Insulated and PVC Sheathed Power Cable
Cable type	Weather Proof Conductor
Number of households connected to the hybrid system	To be specified
Poles	
Type	Wooden or concrete pole
Number of poles	To be specified
Height of poles [m]	At least 2.80 meters according to Thai standard
Other remarks	Pole installation shall be in accordance with PEA standard

7 LOAD PROFILE AND ENERGY CONSUMPTION

Since there are no data loggers at the generators, the load profiles are unknown. The load profile and energy consumption shall be analysed after the load measurements are completed.

7.1 Load Measurements

The Consultant installed two load measurement devices on Koh Bulon Lae on 27th February 2017 to measure the energy consumption of the connected generator loads till 1st April 2017. The devices measure relevant grid parameters like voltage, current, active and reactive power and frequency for each phase separately and were installed in the following grids:

Table 6: Load measurement

Device	Connected to Generator	No. of phases	Number and type of connected houses
LAE 1	Generator #18 (Chaolae Homestay)	1	- 8 residential houses - 8 bungalows - 1 restaurant

LAE 2	Generator #1 (Mrs. Pin)	1	- 4 residential houses - 1 restaurant - 1 water pump (370 W)
-------	-------------------------	---	--

Load Measurement LAE 1:

The first device has been connected to Generator #18 of Chaolae Homestay on 27th February 2017, which consists of 2 generators. They are alternately used to supply the load. The load measurement will be conducted for approx. one month till 1st April 2017.

Table 7: Overview of Generator #18

Parameter	Value
Generator Set 1	
Owner and Operator	Chaolae Homestay
Motor type	YANMAR TF 115 – LM
Continuous Motor Power [kW]	7.2
Power Factor	Unknown
Number of phases	1
Frequency [Hz]	Unknown
Fuel	Diesel
Operating hours	6 pm – 10 pm
Age	> 5 years
Generator Set 2	
Owner and Operator	Chaolae Homestay
Motor type	YANMAR TF 120DI – H
Continuous Motor Power [kW]	7.7
Power Factor	Unknown
Number of phases	1
Frequency [Hz]	Unknown
Fuel	Diesel
Operating hours	10 pm – 6 am
Age	> 5 years
Grid	
Number of connected households	- 8 residential houses - 8 bungalows - 1 restaurant
Cables	10 sq.mm THW-A
Poles	Trees, wooden poles and directly between houses
Condition of the cables	In good condition
Age	> 5 years



Figure 34: Load measurement LAE 1 at Generator #18

Load Measurement LAE 2:

The second device has been connected to Generator #1 owned by Mrs. Pin on 27th February 2017, which supplies 4 residential houses, a restaurant and a water pump. The load measurement will be conducted for approx. one month until 1st April 2017.

Table 8: Overview of Generator #1

Parameter	Value
Generator Set	
Owner and Operator	Mrs. Pin
Motor Type	YANMAR TF 75 – LM
Continuous Motor Power [kW]	4.8
Power Factor	Between 0.8 and 0.9, according to initial load measurement from 27 th to 28 th Feb 2017
Number of phases	1
Frequency	Between 50 Hz and 60 Hz, according to initial load measurement from 27 th to 28 th Feb 2017
Fuel	Diesel
Operating hours	6 pm – 12 am (midnight)
Age	Unknown

Parameter	Value
Grid	
Number of connected households	- 4 residential houses - 1 restaurant - 1 water pump (370 W)
Cables	10 sq.mm THW-A
Poles	Trees, wooden poles and directly between houses
Condition of the cables	In good condition
Age	>5 years

8 ELECTRICITY PRICE STRUCTURE

8.1 Electricity

No common electricity price structure has been implemented on the island. The cost allocation is done via flat rate or individual agreements, meaning each connected house takes turn in buying diesel to run the generator. Since there are no meters installed, the electricity is used based on actual installation and individual agreements.

The data recording, monitoring of actual consumption and the operation and maintenance costs are hardly tracked and recorded. Consequently, the actual generation costs can barely be assessed.

8.2 Diesel

The diesel price consists of 2 parts, the actual diesel price and the transport of the diesel from the mainland to the Island.

The current price per litre diesel paid on the Island is **25 THB/litre**.

The actual transportation costs are considered to be medium-high. A roundtrip costs 300 THB and an estimated maximum of 1,500 l of diesel can be loaded on a long tail boat. Therefore, the delivery price per litre diesel is approximately 0.2 THB (or less than 1% of the actual diesel price) assumed that the boat is properly loaded with the maximum of transport capacity, otherwise the price per litre increases.

The daily, monthly or annual diesel consumption is widely unknown. Nightly diesel consumption is estimated to be 5 litres (e.g. for Generator 1), hence approximately 150 litres per month.

150 litres diesel per month would result in approximately 3,750 THB for diesel and 300 THB for delivery, hence 4,050 THB/month.

8.3 Maintenance Costs and Others

The maintenance cost per Generator is unknown. The Consultant estimated the amount to approximately 12,000-15,000 THB per year for general maintenance, lubricant oil and others.

The price and amount of lubricant oil is so far unknown but considered to be covered in the price stated.

8.4 Summary of Costs

As an example for other generators, the cost structure to operate Generator 1 is summarized in the following.

Generation Costs

Table 9: Actual Generation Costs for Generator 1

Item	THB/Month	Quantity	Total THB/Month
Diesel price	4,050	1	4,050
Maintenance Costs*	1,250	1	1,250
Sum			5,300

*estimated

Cost Sharing Structure

Generator 1 powers the owner's restaurant and 2 houses, plus 2 neighbouring houses. The neighbours pay a fixed rate of 1,000 THB/month to the owner of the generator. The remaining costs are covered by the generator owner.

Table 10: Cost sharing structure for Generator 1

Consumer	THB/Month	Quantity	Total THB/Month
Neighbour Houses	1,000	2 houses	2,000
Owner houses plus Restaurant		2 houses, 1 restaurant	3,300*
Sum			5,300

* Pays the remaining cost

The load measurement shall provide more insight into the actual electricity consumption on the island, thereafter a price per kWh can be estimated.

9 FUTURE ENERGY CONSUMPTION

During the socio-economic survey, the need for future appliances have been assessed. Desires are mainly fridges, washing machines, fans, blender and TVs. Most residents are not keen on having air conditioning. It shall be noted that some ice machines and air conditioners may be planned (case of Mrs. Pin).

10 POSSIBLE AREAS FOR POWERHOUSE

A dedicated area to build a new powerhouse opposite of the school has been identified and reserved. The area provides enough space to construct the powerhouse and a PV system. The area and the boundaries are shown in Figure 35. Site preparation would be required such as tree cutting, backfilling and levelling. The area is close to the beach. However, the transportation of equipment such as inverters, batteries, etc. needs to be clarified since the usual transport landing is at Panka Bay or Panka Noi Bay. The area seems to have low risk for flooding as an open, earth type drainage in the west of the area has been observed.

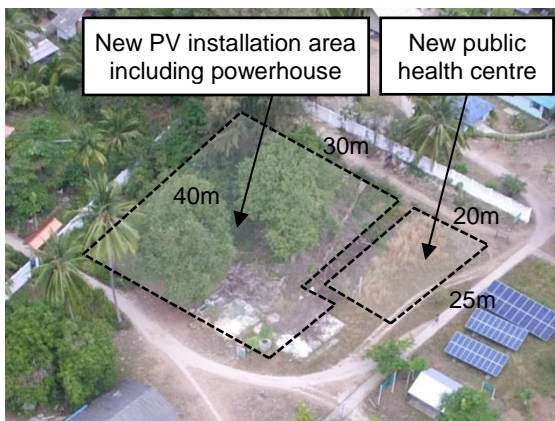

Figure 35: Possible area to install new powerhouse and PV

11 POSSIBLE AREAS FOR PV INSTALLATION

Possible sites for PV installation are mainly around the school area with low risk for flooding.

Table 11: Data summary of pre-selected and reviewed PV areas

Item	Area 1	Area 2	Area 3	Area 4	Area 5	Area 6
GPS coordinates of site	6°49'53.81"N 99°32'30.40"E	6°49'53.72"N 99°32'31.18"E	6°49'52.38"N 99°32'30.17"E	6°49'52.24"N 99°32'30.53"E	6°49'51.56"N 99°32'30.39"E	6°49'53.32"N 99°32'21.16"E
Land owner	School					BTS1 owner
Area borders	1) 6°49'54.21"N 99°32'30.90"E 2) 6°49'54.59"N 99°32'29.51"E 3) 6°49'53.24"N 99°32'29.40"E 4) 6°49'53.09"N 99°32'30.46"E	not necessary	not necessary because of the building (not an open-field area)			not necessary
Size of area	~1,200 m ²	~325 m ²	~150 m ²	~150 m ²	~220 m ²	~15 m ²
Distance to next grid connection	~20 m	~20 m	~20 m	~20 m	~40 m	~10 m
GPS coordinates for grid connection	It cannot be surely clarified the grid connection point since the possible power house /generation location of a hybrid systems needs to be determined					
Size of grid connection point	Existing grid line is 220 V / Based on the Hybrid System Design					
Distance to power house	To be determined					
Slope	~0°	~0°	~15°	~15°	~15°	~0°
Necessity to clear the site	Yes	Yes	No	No	No	Yes
Visible soil conditions	Sandy to clay	Sandy to clay	Rooftop	Rooftop	Rooftop	Clay
Temporary flooding risks	Low	Low	Not observed	Not observed	Not observed	Low
Preferred areas by ILF	Preferred area	Preferred area	Preferred area	Preferred area	Preferred area	Selection shall be considered if BTS owner is willing to connect with the public grid.

11.1 Area 1 to 5: School Area

Figure 36 shows the overview of possible sites to install new PV systems within the school area.

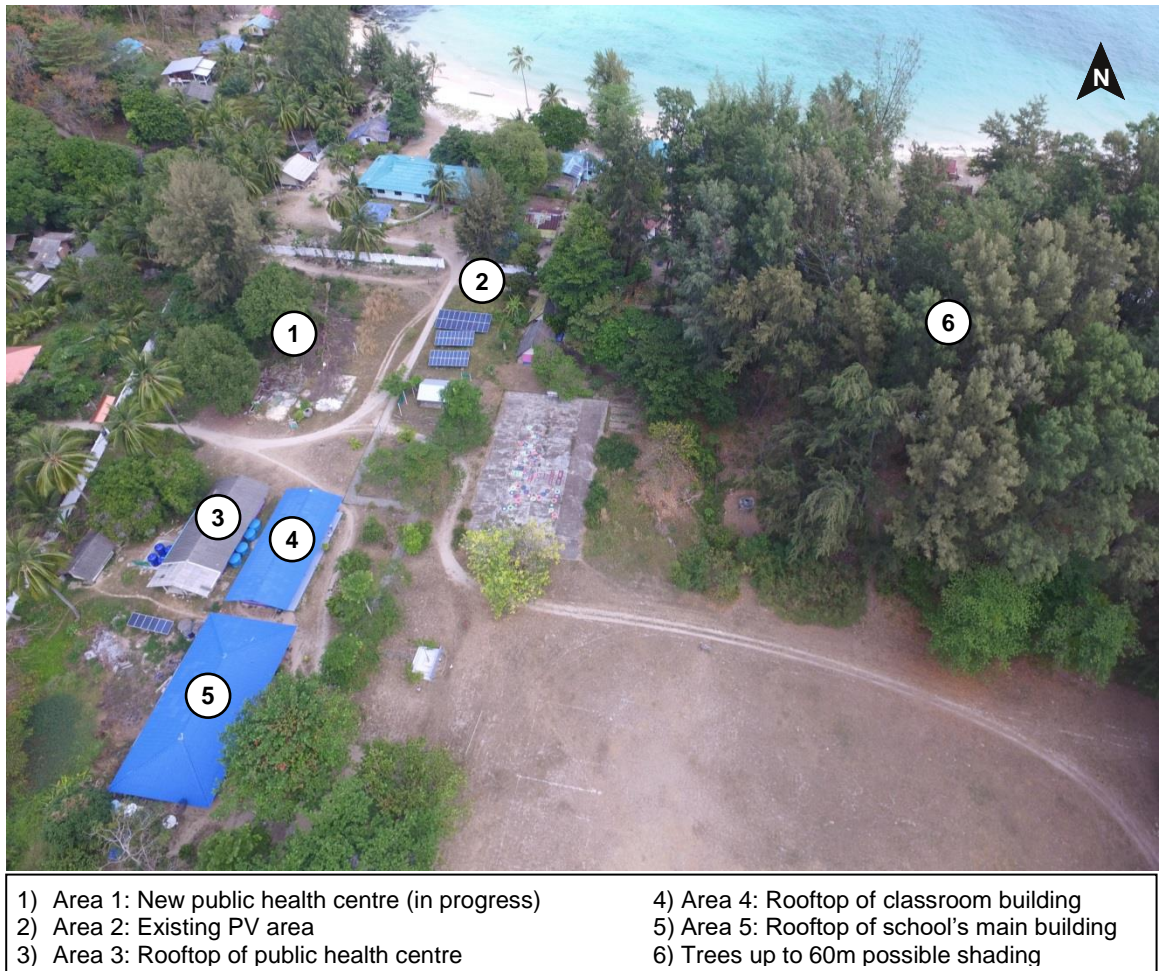

Figure 36: Overview of possible areas to install new PV systems within the school area

Area 1: New public health centre

Figure 35 shows the drone picture of Area 1. In case this area will be used, proper coordination about the exact size (width x length x height) and position of the new public health centre has to be carried out before defining the PV panel positions. Cutting down the trees within this area (see Figure 37) is permitted.



Figure 37: Overview of the new public health centre area

Area 2: Replacement of existing PV system:

Figure 38 shows the drone picture of Area 2. High trees are located in that area provoking some shading in the morning time.



Figure 38: Overview of existing PV at school with area boundaries

For Area 1 and Area 2, shading analysis shall be conducted due to the surrounding trees. Especially trees in the East side (No.6) may cause some shading. The shading might be however limited to the morning period.

Area 3: Rooftop of public health centre:

Figure 39 shows the rooftop sheet and structure of the public health centre. It is a gable roof which has slopes on two sides facing towards East-West direction with an inclination of 15°. The approx. size of the roof is 17 m x 9 m.



Figure 39: Rooftop sheet and structure of the public health centre

Area 4: Rooftop of the classroom building:

Figure 40 shows the rooftop sheet and structure of the classroom building. The roof's configuration is similar to Area 3. However, it seems to be newer.



Figure 40: Rooftop sheet and structure of classroom building

Area 5: Rooftop of the main school building:

Figure 41 shows the rooftop of the school's main building. The type of roof is a hip roof which has 15° slopes on all four sides. The approx. size of the roof is 20 m × 11 m. There are high trees in the Eastern direction that could provoke shade in the morning time.

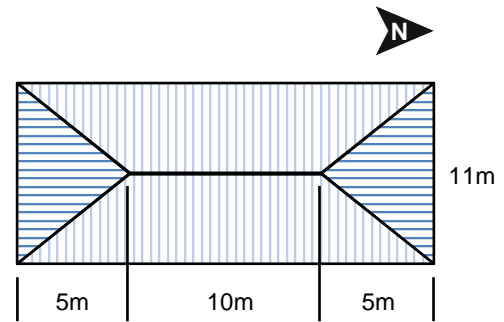

Figure 41: Rooftop of school's main building with approximate sizing

11.2 Area 6: Replacement of Broken SHARP Modules at BTS1 (DTAC, True)

Figure 42 shows twelve broken SHARP modules at BTS1. The approx. size of the area is 3 m x 5.5 m. The usage of the area for a new PV installation shall be clarified with the BTS operator and owner since the connection of a BTS to a hybrid might be complicated and includes several legal and technical impacts. Furthermore, the current ownership/lease-agreement of the land needs to be considered. Therefore, the area shall be least favourable and it is suggested to only consider the area if no other option is available.



Figure 42: Twelve broken SHARP modules at BTS1

12 WATER STORAGE SYSTEM

Figure 43 shows a large pond which collects rain water for the water supply on the island with a capacity of approx. 83,000 m³. The community's diesel water pump serves to distribute the water to each household. There is no fixed operation schedule. Whenever the water is needed, the island's deputy has to be informed, who will then manage to

turn on the water pump. Another diesel water pump was observed close to the pond owned by the Jungle Hut resort.

The diesel water pumps might be replaced with a solar water pump in the future.

Another water source is the deep well pumping underground water located nearby the deputy's house (shown in Figure 44).

Private storage tanks to collect rainwater have been observed in most households as shown in Figure 45.



Figure 43: Large pond with water pumping



Figure 44: Deep well underground water source



Figure 45: private storage tank collecting rainwater

13 LOGISTICS

13.1 Transportation on the Island

Small tractor and motorbikes with sidecar are the common transportation on the island as shown in Figure 46 and Figure 47. A small tractor might be suitable to transport minor loads like solar modules.



Figure 46: Small tractor for transportation on the island



Figure 47: Motorbike with sidecar for transportation on the island [left]; diesel transport to the island [right]

During the site visit, locals stated that heavy equipment, such as big generators are being disassembled prior to shipment and being transported in pieces by long tail boat. The boat will dock at Panka Noi Bay at high tide, afterwards a small tractor will be used to transport the pieces of the generator. Finally, the generator will be re-assembled at the final destination.



Figure 48: Panka Noi Bay at low tide

13.2 Availability of Construction Machinery and Manpower Skills

There are no excavation vehicles available on Koh Bulon Lae. Local manpower skills seem to be low, e.g. no trained electrical installer or engineer. Mr. Mok (owner of Mok mix bar) used to be responsible for the electrical installations. However, since the opening of the bar, his involvement is reduced. Mr. Rit, trying to support in the installation of the ILF measurement device, seems not too confident with electrical installations.

Operation and maintenance of PV modules, batteries, generators, etc. shall be discussed. Training and a clear plan shall be implemented since the local awareness and sensitivity of the technology seems to be low as PV systems are wrongly used, generators not maintained, etc.

Local building material is sand and wood. However, other material such as cement, steel, etc. has been transported from the mainland.

Some labourers from the mainland have been observed during the site visit as shown in Figure 49.



Figure 49: Manpower observed on the island

13.3 Possible Laydown Area and Accommodation Facilities during Execution

The area around the school may be considered as laydown area. There are plenty of resorts for accommodation during the construction phase.

13.4 Roads

The main road of Koh Bulon Lae is made of concrete and is in a good condition. It has a width of approx. 2 m starting from the school to Panka Noi Bay as shown in Figure 50. However, the road to Mango Bay is only a dirt road as shown in Figure 51.



Figure 50: Typical concrete road on Koh Bulon Lae (width approx. 2 m)

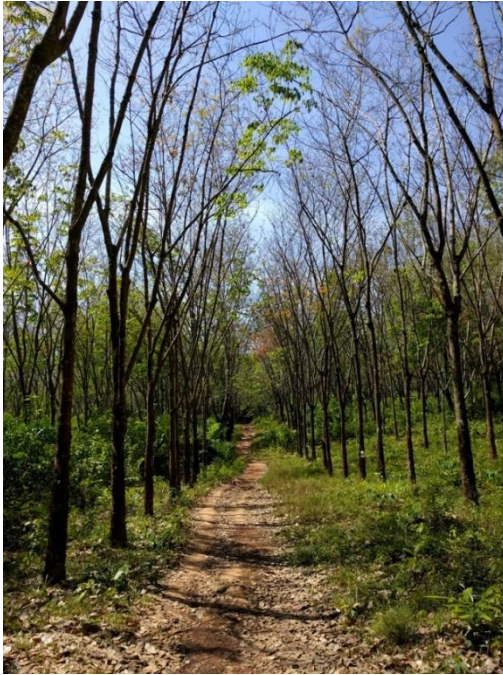

Figure 51: Typical dirt road heading to Mango Bay

13.5 Pier

Mainland Pier

The closest pier to Koh Bulon Lae is Pak Bara Pier, approx. one-and-a-half-hour distance with the local long tail boat. The pier should be sufficient for the shipment of the gear and larger equipment.

Island Pier

There is only a floating pier available located at Mango Bay as shown in Figure 52. Other access routes are boat landings at the different beaches, accessible by small boats – such as long tail boat – only.



Figure 52: Floating pier at Mango Bay

14 APPENDICES

Appendix 1: List of the generators observed during the site visit with the GPS location

No.	Reference No.	GPS	No.	Reference No.	GPS
1	#1	6.83187, 99.53754	23	#21	6.829, 99.53612
2	#2	6.83166, 99.53708	24	#22	6.83098, 99.53782
3	#3	6.83209, 99.53634	25	#23	6.82993, 99.53719
4	#4	6.8314, 99.53718	26	#24a	6.83108, 99.53983
5	#5	6.83013, 99.53661	27	#24b	6.83106, 99.53988
6	#6	6.83002, 99.53716	28	#24c	6.83154, 99.54117
7	#7	6.83, 99.53737	29	#24d	6.8315, 99.54083
8	#8	6.83141, 99.53591	30	#25a	6.83235, 99.54054
9	#9	6.83107, 99.53588	31	#25b	6.83231, 99.5406
10	#10	6.832, 99.53527	32	#25c	6.8323, 99.54055
11	#11	6.83243, 99.5352	33	#26a	6.83118, 99.53985
12	#12	6.83181, 99.53765	34	#26b	6.83119, 99.53992
13	#13	6.83195, 99.53755	35	#27a	6.82858, 99.5395
14	#14	6.83047, 99.53527	36	#27b	6.82854, 99.53962
15	#15	6.82971, 99.53694	37	#28	6.83204, 99.53482
16	#16	6.82775, 99.53636	38	#29a	6.83137, 99.53922
17	#17	6.82828, 99.5365	39	#29b	6.83138, 99.53966
18	#18a	6.8318, 99.53526	40	#30a	6.83128, 99.53943
19	#18b	6.83173, 99.53526	41	#30b	6.83127, 99.5395
20	#19a	6.83061, 99.53601	42	#33a	6.83169, 99.53579
21	#19b	6.83062, 99.53608	43	#33b	6.83169, 99.53579
22	#20	6.83129, 99.53892	44	#34	6.83189, 99.53528

Appendix 2: Generator information observed during the site visit

Reference No.	#1	#2	#3	#4	#12
Generator					
Owner and Operator	Mrs. Pin	Ms. Yuree and Mr. Mok	Mr. Ali	Mr. Suchanya	Mr. Sompong
Continuous Power [kW]	Unknown	3	5	1.76	5.5
Power Factor	Unknown	1.0	0.8	0.8	0.8
Number of phases	1	1	1	1	1
Frequency [Hz]	Unknown	50	50	50	50
Fuel	Diesel	Diesel	Diesel	Benzene	Diesel
Operating hours	6 pm – 6 am	6 pm – 2 am	6 pm – 11 pm	6 pm – 12 pm	6 pm – 12 pm
Age	Unknown	5 years (2012)	10 years	5 years (2012)	3 years (2014)
Grid					
Number of connected households	4 + 1 restaurant	2 + 1 shop + 1 bar	3	1 restaurant	2 restaurants
Cables	50 mm ² , THW-A, 2541 Thai standard year	2x2.5 mm ² , VAF, 2531 Thai standard year	2x2.5 mm ² , VAF, 2531 Thai standard year	2x2.5 mm ² , VAF, 2531 Thai standard year	2x2.5 mm ² , VAF, 2531 Thai standard year
Poles	Either cable lies directly on the ground or trees are used as poles	Either cable lies directly on the ground or trees are used as poles	Either cable lies directly on the ground or trees are used as poles	Either cable lies directly on the ground or trees are used as poles	Either cable lies directly on the ground or trees are used as poles
Condition of the cables	Frequently fixed, should be replaced in case of a renovation	Frequently fixed, should be replaced in case of a renovation	Frequently fixed, should be replaced in case of a renovation	Frequently fixed, should be replaced in case of a renovation	Frequently fixed, should be replaced in case of a renovation
Age	> 5 years	5 years (2012)	10 years	5 years (2012)	3 years (2014)

Generator information observed during the site visit (con't)

Reference No.	#18a	#18b
Generator		
Owner and Operator	Chaolae Homestay	Chaolae Homestay
Continuous Power [kW]	8.8 kW (max output)	8.46 kW (max output)
Power Factor	Unknown	Unknown
Number of phases	1	1
Frequency [Hz]	Unknown	Unknown
Fuel	Diesel	Diesel
Operating hours	6 pm – 4 am (high season) 8 am – 10 pm (low season)	
Age	Unknown	Unknown
Grid		
Number of connected households	8 residential households, 8 bungalows 1 restaurant	
Cables	16 mm ² , THW-A, 2541 Thai standard year	2x2.5 mm ² , VAF, 2531 Thai standard year
Poles	Cables fixed to purlin used as poles	Cables fixed to purlin used as poles
Condition of the cables	Transmission cable and generator cable are in good condition	Transmission cable is in good condition. However, cable type from generator is not a proper type.
Age	Unknown	Unknown

Appendix 3: Summary of PV System

Location	SHS			BTS1		
PV Module						
Brand	Solartron	NS (Northern Sunshine)	SHARP	CanadianSolar	Hanwha	Hanwha
Model	SP120	NS 130C	NT-S5E3E	CS6X-300P	HSL60M6-HA-1-250	HSL60M6-HA-1-255
Max power	120 W	130 W	185 W	300 W	250 W	255 W
Voltage max power	17.28 V	17.60 V	36.21 V	36.1 V	30.5 V	30.7 V
Current max power	7.0 A	7.38 A	5.11 A	8.30 A	8.2 A	8.32 A
Open Circuit Voltage	21.7 V	22.20 V	44.9 V	44.6 V	37.2 V	37.4 V
Short Circuit Current	7.45 A	7.93 A	5.60 A	8.87 A	8.7 A	8.82 A
Facing	Various	Various	South-West	South-West	N/A	N/A
Inclination	Various	Various	15°	15°	N/A	N/A
Battery						
Brand	N/A	N/A	N/A	N/A	N/A	N/A
Model	N/A	N/A	N/A	N/A	N/A	N/A
Voltage	N/A	N/A	N/A	N/A	N/A	N/A
AH	N/A	N/A	N/A	N/A	N/A	N/A
Notes	N/A	N/A	N/A	N/A	N/A	N/A

Summary of PV System (con't)

Location	BTS2	School			Public health centre	Mosque
PV Module						
Brand	Solartron	Solartron	Q CELLS	Solartron	Schutten	Solartron
Model	SP130	SP130	Q.PRO L 300	SP120	STP6-250/60	SP120
Max power	130 W	130 W	300 W	120 W	250 W	120 W
Voltage max power	17.00 V	17.00 V	36.11 V	17.28 V	30.20 V	17.28 V
Current max power	7.70 A	7.70 A	8.31 A	7.0 A	8.30 A	7.0 A
Open Circuit Voltage	22.0 V	22.0 V	45.13 V	21.7 V	37.75 V	21.7 V
Short Circuit Current	8.20 A	8.20 A	8.91 A	7.45 A	8.98 A	7.45 A
Facing	South	South	South	South	South	N/A
Inclination	N/A	15°	15°	N/A	N/A	N/A
Battery						
Brand	N/A	Torch	VARTA	GLOBATT	GLOBATT	3K
Model	N/A	GGM(OPzS) 1000	7 OPzS 490	N100-LST	INVA 150	N/A
Voltage	N/A	2 V	2 V	12 V	12 V	N/A
AH	N/A	1000 AH	490 AH	100 AH	150 AH	N/A
Notes	To be assumed the same as the system at school	Supplying the school	Supplying the BTS1	Supplying the teacher resting building only	Suppling the public health centre only	The system is currently not in-use because of the broken inverters

Appendix 4: Site Survey Overview

See separate document: "2_Bulon Lae_Survey Evaluation_final"