

# Hybridization of Islands, Thailand

## SITE VISIT REPORT KOH MAK NOI

01/05/2017

**ILF Consulting Engineers (Asia) Ltd**

88 Dr Gerhard Link Building (B.Grimm), 12<sup>th</sup> Floor  
Krungthepkreetha 99 Rd. (Soi 4)  
Huamark, Bangkapi, Bangkok 10240  
THAILAND

frank.zimmermann@ifl.com

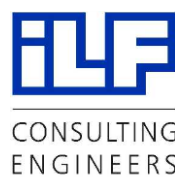

## TABLE OF CONTENTS

1	INTRODUCTION	7
2	ISLAND GENERAL OVERVIEW	8
3	SOCIO-ECONOMIC SITUATION	9
	3.1 Demographic	9
	3.2 Education	9
	3.3 Occupation, Local business and Economic Situation	9
	3.4 Typical Appliances	9
	3.5 Community Spirit	10
	3.6 Local Resources	10
4	DIESEL GENERATORS	11
	4.1 Generator #40 (owned by Mr.Abdullah)	12
	4.2 Generator #41 (owned by Mr.Abdullah)	12
	4.3 Generator #62 (owned by Mr.Usop)	13
	4.4 Generator #66 (owned by Mr.Weerachai)	13
	4.5 Generator #68 (owned by Mr.Shade)	14
5	EXISTING PHOTOVOLTAICS SYSTEMS	15
	5.1 Solar Home Systems	15
	5.2 Mosque PV-Battery System	15
	5.3 BTS PV System	16
	5.4 School PV-Battery System	17
	5.5 Public Health Centre PV-Battery System	18
	5.6 PV-Wind-Battery Hybrid System	19
6	GRIDS	20
	6.1 Cables	21
	6.2 Cable Anchoring	24
	6.3 Switchgear	26
	6.4 Grid Stability and Conditions	28
	6.5 Grid Recommendations	28

7	LOAD PROFILE AND ENERGY CONSUMPTION	30
	7.1 Load Measurements	30
8	ELECTRICITY PRICE STRUCTURE	30
	8.1 General	30
	8.2 Electricity	31
	8.3 Diesel	31
	8.4 Maintenance Costs and Others	32
	8.5 Summary of Costs	32
9	FUTURE ENERGY CONSUMPTION	34
10	POSSIBLE AREA FOR POWERHOUSE	34
11	POSSIBLE AREAS FOR PV INSTALLATION	36
	11.1 Area 1-3: Public Health Centre	40
	11.2 Area 4-5: School Area	41
	11.3 Area 6-8: Mosque Area	42
	11.4 Area 9: Mr. Abdullah's Area	44
	11.5 Area 10-11: Open-Field Area Closed to Seashore	45
12	WATER STORAGE SYSTEM	46
13	LOGISTICS AND INFRASTRUCTURE	47
	13.1 Transportation on the Island	47
	13.2 Construction and construction vehicles	48
	13.3 Trained manpower	48
	13.4 Possible laydown area and accommodation facilities during execution	49
	13.5 Roads	49
	13.6 Pier	49
	13.7 Fuel transport to the island	51
14	FUTURE PLANS FOR SUBMARINE CABLE CONNECTION	51
15	APPENDICES	53

## FIGURES

Figure 1: Project location	7
Figure 2: Island overview with public buildings/locations (Source: Google Earth taken in 2016)	8
Figure 3: Location of 5 generators on Koh Mak Noi	11
Figure 4: Powerhouse of Generator #40 within the mosque area	12
Figure 5: Generator #41	13
Figure 6: Generator #62 under the corrugated sheet roof	13
Figure 7: Generator #66	14
Figure 8: Generator #68	14
Figure 9: Overview of PV system locations on the island	15
Figure 10: PV-Battery system supplying the electricity for the mosque	16
Figure 11: PV system at BTS	16
Figure 12: Sketch-drawing of PV of the BTS	17
Figure 13: School PV system	17
Figure 14: Rusty combiner box and thin film modules	18
Figure 15: 2 kW <sub>p</sub> PV system powering the public health centre	18
Figure 16: Dirty crystalline solar modules	19
Figure 17: Details of the wind turbine (left) and schematic connection details (PV System not up to date) (right)	20
Figure 18: PV-Wind-Battery hybrid system located at pond	20
Figure 19: The five major grids of Koh Mak Noi	21
Figure 20: VAF cable (white cable) connected with THW-A cable (black cable)	22
Figure 21: 25 sq.mm THW–A cable in Grids of Generator #40 and Generator #41	22
Figure 22: VAF cable in Grid of Generator #62	23
Figure 23: Cables in Grid of Generator #68	23
Figure 24: Cables in Grid of Generator #66	24
Figure 25: Wooden stick as a pole and tree connection	25
Figure 26: Old PVC water pipe and concrete pole	25
Figure 27: Ground lying cable transmission connected to Generator #62 (white cable)	26

Figure 28: Switchgear for Generator #40 with four switches [1 – 4], four fuses [I] and partly open switch covers [II].	27
Figure 29: SLD of the Generator #40 System	28
Figure 30: Proposed transmission lines on Koh Mak Noi	29
Figure 31: Two possible locations for new power house	34
Figure 32: Wooden poles of an existing transmission line	35
Figure 33: Possible area for new power house with the abandoned building	36
Figure 34: Overview of 11 possible PV installation areas	37
Figure 35: Possible area to install new PV system at public health centre (Area 1)	40
Figure 36: Two possible areas behind public health centre (Area 2-3)	41
Figure 37: Roof overview and structure of new school building (Area 4)	42
Figure 38: Existing PV area at school (Area 5)	42
Figure 39: Overview of mosque area (Area 6-8)	43
Figure 40: Roof structure and roof sheet of religion learning building (Area 6)	44
Figure 41: Mosque roof (Area 8)	44
Figure 42: Overview of Abdullah's area (Area 9)	45
Figure 43: Soil condition of Abdullah's area (Area 9) and small pond	45
Figure 44: Open-field area (Area 10-11)	46
Figure 45: Water storage system with two large ponds	47
Figure 46: Motorbikes with- and without sidecar.	47
Figure 47: Excavator and manual concrete mixer	48
Figure 48: Pick-up for excavated material	48
Figure 49: Typical road on Koh Mak Noi	49
Figure 50: Laem Sak pier at low tide	50
Figure 51: Koh Mak Noi pier	51
Figure 52: Gasoline for sell observed on the island	51

## TABLES

Table 1: Locations of main generators in Figure 3	11
---	----

Table 2: Cable types	21
Table 3: Pole types	24
Table 4: Proposed setup of the new grid	29
Table 5: Load measurement	30
Table 6: Actual Generation Costs for Generator #40	33
Table 7: Actual Generated Income from Generator #40	33
Table 8: Generation Cost Summary	33
Table 9: Data summary of pre-selected and reviewed PV areas	38

## **APPENDICES**

Appendix 1: List of the generators observed during the site visit with GPS location	53
Appendix 2: Generator information observed during the site visit	54
Appendix 3: Summary of PV Systems	55
Appendix 4 – Site Survey Overview	56

## 1 INTRODUCTION

The Deutsche Gesellschaft für Internationale Zusammenarbeit (GIZ) is assessing a project for the hybridization of two Thai islands in the Andaman Sea. The target of the study is to select two out of three islands for the design and development of a technical and financial feasible hybrid system using a combination of photovoltaics (PV), batteries and diesel generators to supply large parts of the islands with one power generation system (the Project).

Koh Mak Noi is one of three islands for the Project. The island is located in the Andaman Sea between Krabi and Phuket. The current power generation relies on large diesel generators, which supply either grids with up to 101 households or smaller units powering single households.

A site visit was conducted on 2<sup>nd</sup> of March 2017 to analyse the load of the islands, the condition of the existing grids, to identify suitable areas for the installation of PV, batteries and powerhouse, to determine possible long-term impacts and changes of the future energy demand and to investigate the socio – economic situation of the island.



Figure 1: Project location

## 2 ISLAND GENERAL OVERVIEW

The island of Mak Noi is located in the Andaman Sea in Phang-Nga province approx. 5 km West of Laem Sak pier. The current power supply of Koh Mak Noi relies mostly on 5 major grids, each with a single large diesel generator, operated privately. The operators run the generators for approx. 4 hours a day and charge a fixed price per household. There are smaller generators powering single households that are not connected to any of the grids or they serve as a backup to those that are connected. Additionally, around 100 Solar Home Systems (PV and Battery) are installed to power the households when the generators are off.

Approximately 1,400 inhabitants are living on Koh Mak Noi in 250 households, concluding approximately 4.1 residents per household. The economy of the island relies mainly on rubber production, coconut farming, fishery, restaurants, grocery and motorbike repair services. Main public buildings on the island are the health centre, school and mosque. No street lighting, traffic lights or other electric infrastructure has been observed. The region is usually impacted by strong rains during the rainy season, while dry conditions and heat occurs during summer time. A drainage system has not been observed on the island.

A Base Transceiver Station (BTS) was built and owned by DTAC. The mobile signal and internet data are good for DTAC only. AIS and True have limited signal.

Figure 2 provides an overview of the island and highlights important landmarks, buildings and others.

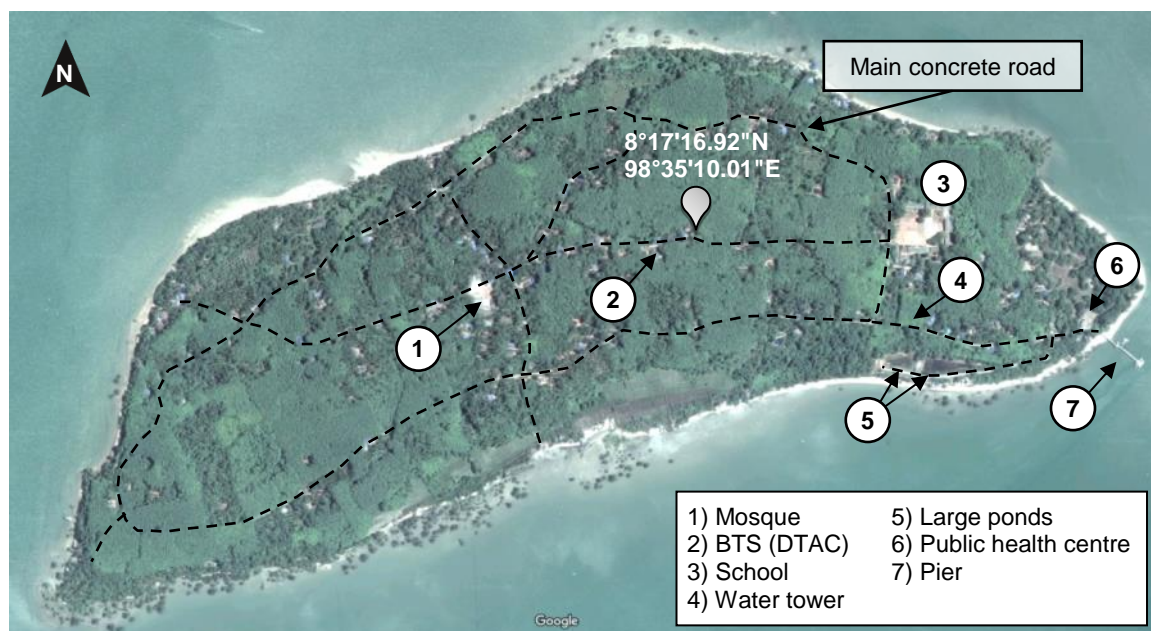

Figure 2: Island overview with public buildings/locations (Source: Google Earth taken in 2016)

### **3 SOCIO-ECONOMIC SITUATION**

#### **3.1 Demographic**

According to SAO website, the number of the registered population and households in 2009 are 1,406 and 259 respectively. The number of population and households in 2016 are 1,400 and 250 respectively. The number of population and households seem to be stable.

The age group distribution on the island is mostly older people and children. Teenagers have barely been seen because they leave the island for higher education. Middle age people are mostly working outside of the island, i.e. tourism industry in Phuket and Krabi. They come back to the island to visit their family once in a while but not for long time periods. Gender seems to be balanced.

Visitors to the islands are uncommon as there are no touristic attractions and only 1-2 touristic bungalows. Future expansion of tourism appears to be very limited and will therefore not impact the future load.

#### **3.2 Education**

Koh Mak Noi School is the only school on the island. It was established in 2005 and provides education from Kindergarten to grade 9. There are approx. 250 students and 21 teachers. For higher education, the students have to leave the island to study onshore. There are 6 classroom buildings and at the time of the site assessment, the school was constructing a new classroom building.

#### **3.3 Occupation, Local business and Economic Situation**

The main occupation is fishery, rubber plantation and coconut plantation. Some are technicians/mechanics that operate motorbike repair shops and boat building/fixing businesses. Around 30 technicians were trained by a university to maintain Solar Home Systems, they can diagnose and fix the systems. There are also shops and a couple of grocery stores mostly selling daily products and gasoline for the motorcycles.

The average income of the population is widely spread ranging from approx. 1,000 THB/month to over 90,000 THB/month, averaging around 7,500 THB/month (mode average).

#### **3.4 Typical Appliances**

The extracted data shows that typical household appliances are lighting, TV, mobile phone and fan. Some households also have washing machines, radios, rice cooker and

electric irons. The motorbike repair shops and boat building/fixing have certain power tools (e.g. drills, saws, sanding tools etc.).

Besides the households, there are several public buildings such as the health centre, school and the mosque. These types of buildings are mostly equipped with common electrical devices such as lighting, TV, fan, computer and printer. Usual business hours as well as school time are approx. from 8:00am to 4:30pm.

### **3.5 Community Spirit**

In general the people are well connected and know each other as they are mainly descendants from a few families. The close relatives generally live together in one premise, which are in some cases a cluster of 3-4 houses. There are no established community cooperatives, groups or social entities. As a remark, the water supply was used to be operated under a community committee, but it didn't work well and it is now Mr. Abdullah taking care of the water supply.

Between the electricity operators and the households, there are some small conflicts. On the operator side, there are issues on delayed payments (up to a month) and secretly using washing machines/irons without paying more, which may cause brownouts/blackouts. Some people also blame it on the operator (or on other users using iron/washing machines) that their appliances broke down because of low electricity quality.

### **3.6 Local Resources**

There are 2 large ponds collecting rain water which are the main water resources on the island. The water storage and supply situation is explained in detail in Chapter 12.

Currently a lot of villagers are operating and maintaining diesel generators, which means they have a certain technical know-how the Project can build upon. Most houses are also constructed by themselves which may promise support in construction work for the Project.

#### 4 DIESEL GENERATORS

Approximately 50 generators are installed on the island, which are either used to power single households or supply multiple households via separate grids (5 operator of large generators). Due to the time constraint during the site visit, only those 5 generators and 5 grid transmission lines, which cover almost all the households, were evaluated during the site visit. All generators observed on the island are listed in Appendix 1.

Figure 3 shows the locations of these 5 generators with 5 different grid transmission lines from the largest to smallest grids, which are the light blue (Mr.Abdullah), grey (Mr.Abdullah), brown (Mr.Shade), green (Mr.Weerachai) and dark blue (Mr.Usop) respectively, i.e. each colour means 1 grid transmission line. An overview of each generator forming a grid is explained in detail in this chapter.

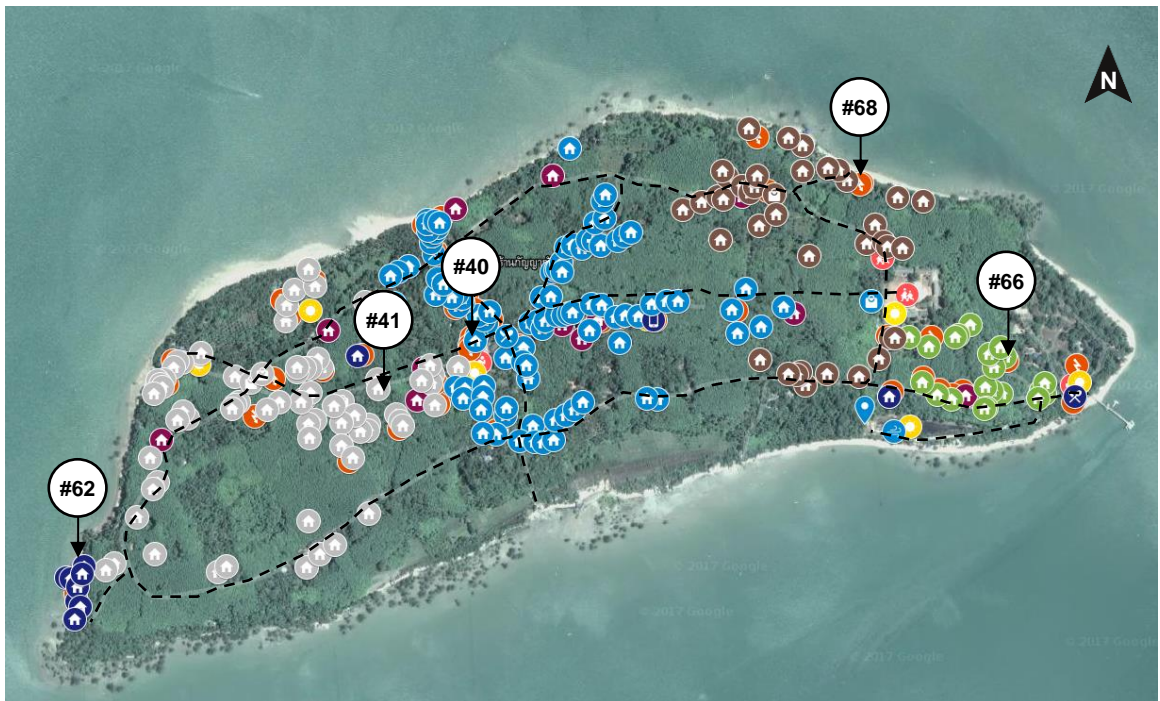

Figure 3: Location of 5 generators on Koh Mak Noi

Table 1 summarizes the owner and the number of connected households of each generator that forms a large grid. As mentioned above, it can be seen that these 5 generators cover almost all households on the island. The detailed specifications of these generators are listed in Appendix 2.

Table 1: Locations of main generators in Figure 3

No.	Generator	Owner and Operator	No. of connected households
1	Generator #40	Mr. Abdullah	101 (light blue icon)
2	Generator #41	Mr. Abdullah	Approx. 70 (grey icon)
3	Generator #62	Mr. Usop	8 (dark blue icon)

No.	Generator	Owner and Operator	No. of connected households
4	Generator #68	Mr. Shade	38 (brown icon)
5	Generator #66	Mr. Weerachai	Approx. 20 (green icon)

It has to be noted that this chapter only describes the generators; the grids shall be described in detail in Chapter 6.

#### 4.1 Generator #40 (owned by Mr. Abdullah)

The generator is located in the power house of the mosque compound, supplies approximately 100 households and is operated by Mr. Abdullah. It is the biggest grid of the island. The grid was set up three years ago by Mr. Abdullah.



Figure 4: Powerhouse of Generator #40 within the mosque area

#### 4.2 Generator #41 (owned by Mr. Abdullah)

The generator is located in a power house approximately 400 m west of the mosque along the road. Around 70 households are connected to this generator. It is also owned and operated by Mr. Abdullah and connected to the second biggest grid on Koh Mak Noi. The grid was set up three years ago by Mr. Abdullah.



Figure 5: Generator #41

#### 4.3 Generator #62 (owned by Mr. Usop)

The generator is housed under a rusty corrugated sheet roof and supplies 8 households. It is located on the far West of Koh Mak Noi, owned and operated by Mr. Usop.



Figure 6: Generator #62 under the corrugated sheet roof

#### 4.4 Generator #66 (owned by Mr. Weerachai)

The generator is located in the East of the island and supplies approx. 20 households. The powerhouse is made of corrugated metal sheets. The generator is owned and operated by Mr. Weerachai. Figure 7 shows Generator #66. The switchgear is located on the table under a blanket.



Figure 7: Generator #66

#### 4.5 Generator #68 (owned by Mr. Shade)

The generator is located on the North-Eastern coast of Koh Mak Noi and supplies 38 households. In the same powerhouse, a second 12 kW generator is installed to supply power tools for metal works, e.g. 13 kW welding machine, lathe machine, etc.



Figure 8: Generator #68

## 5 EXISTING PHOTOVOLTAICS SYSTEMS

Figure 9 shows the location of the existing PV systems on Koh Mak Noi. Solar Home Systems are not shown in Figure 9 since they are installed and utilized by households spread out across the island. The detailed specifications of each system are listed in Appendix 3.



Figure 9: Overview of PV system locations on the island

### 5.1 Solar Home Systems

There are around 100 functional Solar Home Systems on Koh Mak Noi. Such Solar Home Systems originate from governmental support. Initially around 250 Solar Home systems have been supplied. However due to a lack of maintenance and knowledge only around 100 systems are currently in operation and partially or fully operating.

The Solar Home Systems typically comprise one PV Module from Solartron with 120 W<sub>p</sub> and are connected via a charge controller and inverter to a battery (100Ah, 12 V) to supply selected appliances of the house.

### 5.2 Mosque PV-Battery System

Besides the diesel generator, electricity for the mosque is also supplied with a PV-battery system consisting of 9 and 15 PV modules of Solartron 50 W<sub>p</sub>, 53 W<sub>p</sub> respectively – as shown in Figure 10.

The total power of 1.245 kW<sub>p</sub> is connected via a charge controller to 4 batteries of GS model N120 (specification of battery: nominal voltage 12V, capacity 120Ah). The system

is connected via a bidirectional inverter Leonics model Apollo S-210 series to the electrical system of the mosque. The PV system is facing towards South with an inclination of 5°. The system was initially built and installed as a rooftop system, but the roof of the mosque has been maintained and a new roof sheet was installed. Therefore, the system has been moved and mounted on the ground and was not re-installed on the roof.



Figure 10: PV-Battery system supplying the electricity for the mosque

### 5.3 BTS PV System

Figure 11 shows the PV/Hybrid system owned by DTAC. The solar modules are facing South with an inclination of 20°. The system comprises of 56 PV modules of SHARP 130  $W_p$  and 19 PV modules of Canadian Solar 300  $W_p$ , summarizing to a 12.98  $kW_p$  system. The first table in the Southern side is completely shaded by surrounding trees.

The system connects with a 26.4 kW diesel generator, which currently consumes approx. 3,000 litre/month. The entire system may be considered as a small hybrid system. The system appears to sufficiently power the BTS. The system is operated in an automatic mode; however, nearby household members are engaged to refill diesel fuel.



Figure 11: PV system at BTS

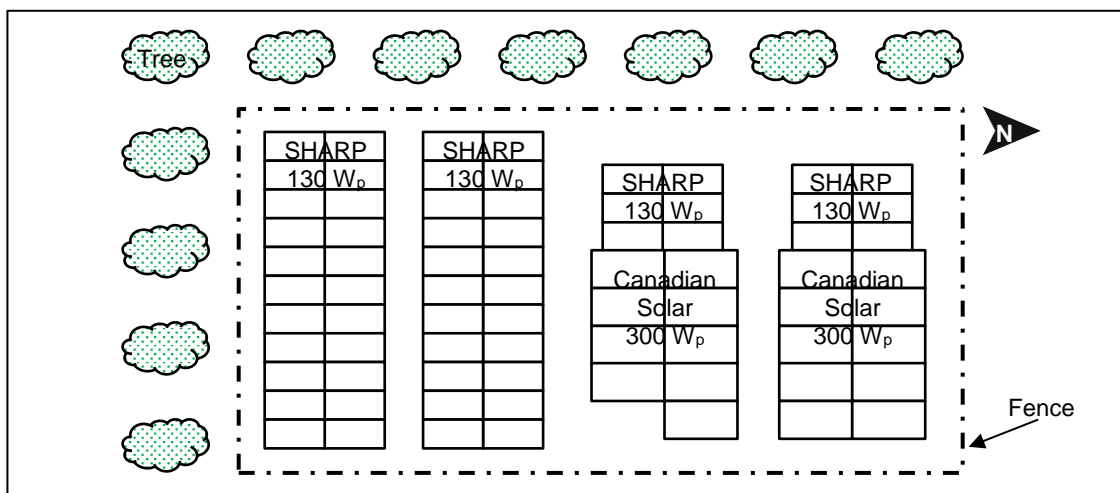

Figure 12: Sketch-drawing of PV panels at the BTS

#### 5.4 School PV-Battery System

Figure 13 shows the PV system at the school, totalling 5.12 kW<sub>p</sub>. It consists of 80 modules type Uni-Solar 64 W<sub>p</sub> connected via charge controller to 23 batteries of Union model 8 OPZS 800 (specification of battery: nominal voltage 2V, capacity 800Ah) and 4 batteries of NEC. For clarification purposes, the 48 V system consisted originally of 24 cells, whereas 1 of them is currently disconnected. The system is connected to a true sine wave inverter supplying the electricity to the school only. The system is facing towards South with an inclination of 20°.



Figure 13: School PV system

The combiner box appears to be dangerously rusty. The functional status of the solar modules shall be checked, as the thin-film modules seem to shimmer strongly, as shown in Figure 14.



Figure 14: Rusty combiner box and thin film modules

It shall be noted that the director of the school is not keen on supplying electricity generated on the school premises with the community but would appreciate to receive and upgrade to the current school system. Therefore, the school might be considered as integral consuming part in a community hybrid system.

## 5.5 Public Health Centre PV-Battery System

The public health centre of Koh Mak Noi is electrically independent. The supply of electricity originates from a PV-battery system as shown in Figure 15. The system was built in 2006. The system comprises of 16 PV modules of Solartron 125 W<sub>p</sub>, resulting in a 2 kW<sub>p</sub> system. This is connected via charge controller to 8 batteries of 3K model EB160T (specification of battery: nominal voltage 12 V, capacity 190 Ah/20 h). The system supplies electricity via an inverter to the electrical system of the public health centre. Whether the inverter is trapezoid or sinewave could not be clarified. The PV system is facing towards South direction with an inclination of 15°.



Figure 15: 2 kW<sub>p</sub> PV system powering the public health centre

As shown in Figure 16, the solar modules were observed dirty, lacking also some maintenance-efforts.

The representatives of the health centre seem to be interested to upgrade the electricity system and shall be considered to be integral part of a hybrid system.



Figure 16: Dirty crystalline solar modules

## 5.6 PV-Wind-Battery Hybrid System

Figure 18 shows the PV-Wind-Battery hybrid system installed in 2011 solely supplying the electricity for water pumping. A detailed description of the water storage system is provided in chapter 12. The system is located close to the pond in the South of the island. The PV system comprises of 16 PV modules of Solartron 130  $W_p$  and 12 PV modules of presumably 250  $W_p$ . There was no nameplate for the 60-cell modules. Both are facing towards the South. 5 wind turbines with a capacity of 1  $kW_p$  each, hence 5  $kW_p$  nominal capacities are installed and integrated with the PV and battery system. The inverters, charge controllers and 12 batteries of Yuasa model EB130 (specification of battery: nominal voltage 12V, capacity 130Ah) are located in the powerhouse. There is an access road with a width of approximately 5 m.

During the site visit, the PV modules and wind turbines were charging the batteries. The water pump connected to the hybrid system is currently out of order. The wind turbines were hardly rotating since the observed low wind speed was not sufficient for the cut-in speed (3.5 m/s) of the turbines and thus the application of the wind turbines may be critically questioned.



Figure 17: Details of the wind turbine (left) and schematic connection details (PV System not up to date) (right)

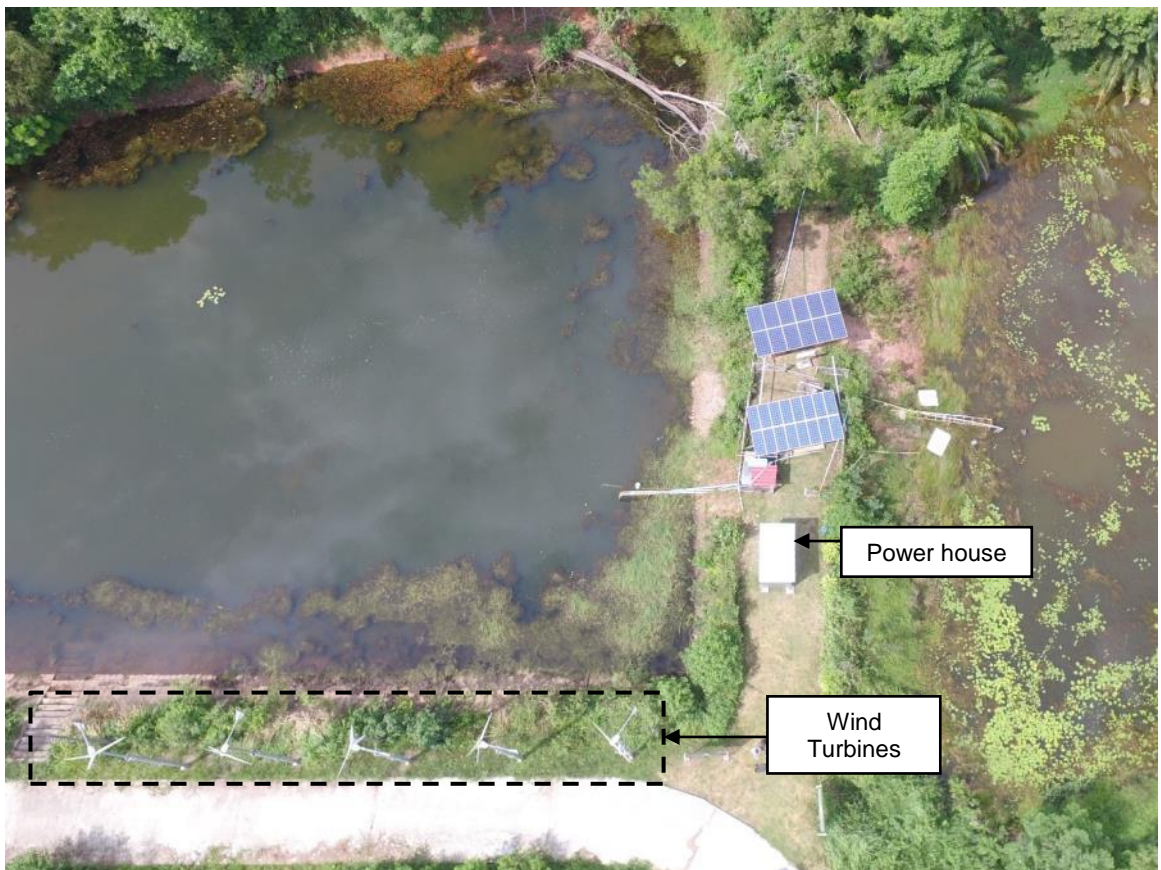

Figure 18: PV-Wind-Battery hybrid system located at pond

## 6 GRIDS

There are five major grids on Koh Mak Noi supplying approx. 235 households. Each of these grids is connected to one of the five generators described in Chapter 4. There is no interconnection between these five grids. Figure 19 shows the 5 major grids on the island from the largest to smallest grids, which are the light blue (Mr.Abdullah), grey

(Mr.Abdullah), brown (Mr.Shade), green (Mr.Weerachai) and dark blue (Mr.Usop) respectively. Therefore, there are 3 major operators, i.e. Mr.Abdullah, Mr.Share and Mr.Weerachai, selling the electricity on the island. The electricity price is described in detail in Chapter 8.

Furthermore, there is a small existing grid around the PV-Wind-Battery system which is currently not in use as described further in Chapter 10.

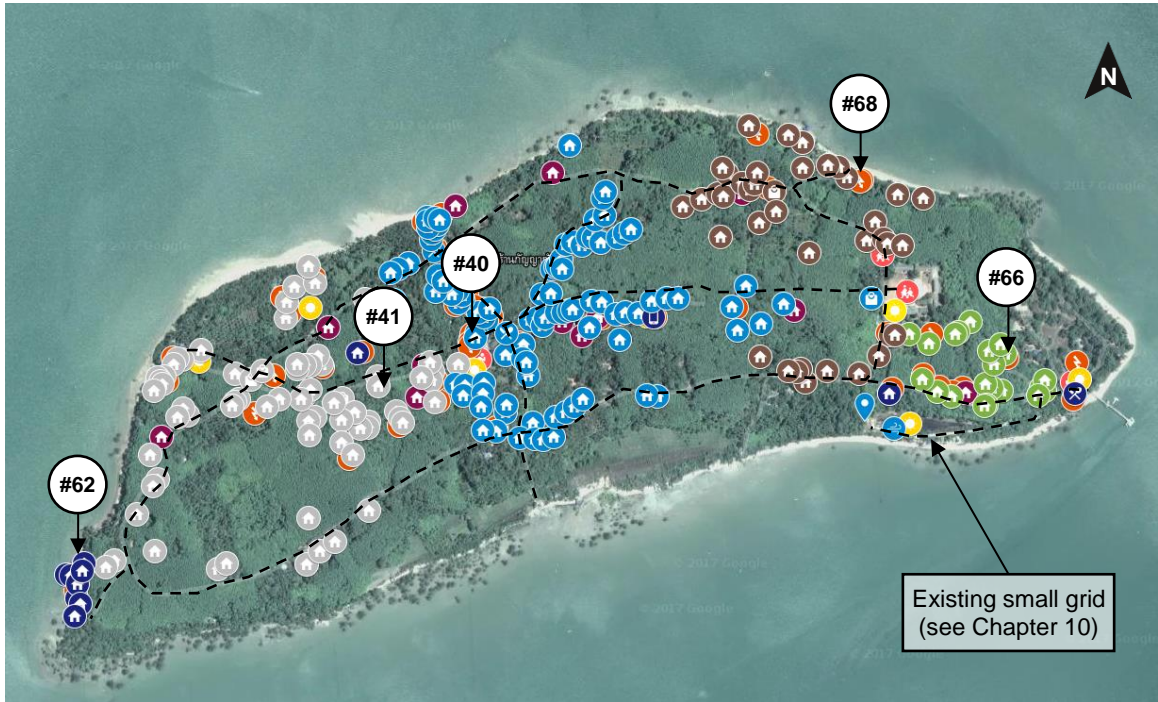

Figure 19: The five major grids of Koh Mak Noi

### 6.1 Cables

The observed cable specifications on the island are summarized for each grid in the following table:

Table 2: Cable types

Cross-section	Spec.	Thai Standard year	Manufacturer	Connected to Generator
2x2.5 mm <sup>2</sup>	VAF	2553	Bangkok cable	#40, #41, #68, #66
2x1.5 mm <sup>2</sup>	VAF	2553	Bangkok cable	#62
10 mm <sup>2</sup>	THW-A	2541	United wire & cable Co. Ltd., Bangkok cable	#40, #66
16 mm <sup>2</sup>	THW-A	2541	United wire & cable Co. Ltd.	#40, #68
25 mm <sup>2</sup>	THW-A	2541	Thai union wire	#40, #41

### Grids of Generator #40 and Generator #41

These two grids were installed three years ago by Mr. Abdullah and are very similar in terms of the used cables. The main part of these grids consist of the THW–A cables. In the meantime, the insulation of these cables has been fixed and repaired several times, consequently replacing the cables should be considered, if a new grid will be installed on Koh Mak Noi.

The VAF cables have been used to connect households to the main grid (THW-A) as shown in Figure 20, this cable has been used to connect households in a later stage, after the main grid has been installed. According to Thai standard, the VAF cable should not be exposed to sunlight directly, in other words, the cable should be used for indoor or inside use only.



Figure 20: VAF cable (white cable) connected with THW-A cable (black cable)



Figure 21: 25 sq.mm THW–A cable in Grids of Generator #40 and Generator #41

### Grid of Generator #62

This grid uses only the 2x1.5 mm<sup>2</sup> VAF cables to connect between households. The insulation of these cables has been fixed and repaired several times, consequently replacing the cables should be considered, if a new grid will be installed.



Figure 22: VAF cable in Grid of Generator #62

Grid of Generator #68

This grid uses the 16 mm<sup>2</sup> THW–A cables to connect additional houses. The insulation of these cables is still in a good condition. Due to the size of the cables, replacement might be required if a new grid will be installed.



Figure 23: Cables in Grid of Generator #68

Grid of Generator #66

This grid uses the 10 mm<sup>2</sup> THW–A for main transmission line and 2x2.5 mm<sup>2</sup> VAF cables to connect additional houses. The insulation of these cables has been fixed and repaired several times, consequently replacing the cables should be considered, if a new grid will be installed.



Figure 24: Cables in Grid of Generator #66

## 6.2 Cable Anchoring

All grids use one of the following methods for the cable transmission.

Table 3: Pole types

Type	Frequency
Wooden sticks	Most common pole type
Trees	Common
Old PVC water pipes	Seldom
Ground lying	Seldom (Mr. Usop's grid and few parts of the mosque grid)
Concrete poles	In some parts of Mr. Weerachai's grid

According to Thai standard, the cables should usually be installed in a height of at least 2.5 m above the ground. This is not the case on Koh Mak Noi since poles are lower and cables are not professionally attached to the poles, i.e. the tension and suspension strategy of poles is not observed. This results in cables hanging down between poles in a height that humans or animals may accidentally get in contact. Technical safety of the grid does not exist. The grid might be damaged due to unpredictable incidents such as animal crossings or storm, etc.



Figure 25: Wooden stick as a pole and tree connection



Figure 26: Old PVC water pipe and concrete pole



Figure 27: Ground lying cable transmission connected to Generator #62 (white cable)

### 6.3 Switchgear

Each of the 5 major grids uses manual switches to disconnect the generators from the load. These switches are used to protect the load from the starting current of the generator. Several of the switches are in a bad condition with blank metal parts, which may result in hazardous electric shocks, if touched in operation.

- With exception of the Grid of Generator #40 no fuses are installed to protect the load from overcurrent.
- Furthermore, all grids are lacking residual current devices (RCD) to protect people from overcurrent
- no surge arresters are installed to protect the loads in case of a lightning strike

A new system has to include these safety devices to protect people and connected loads.

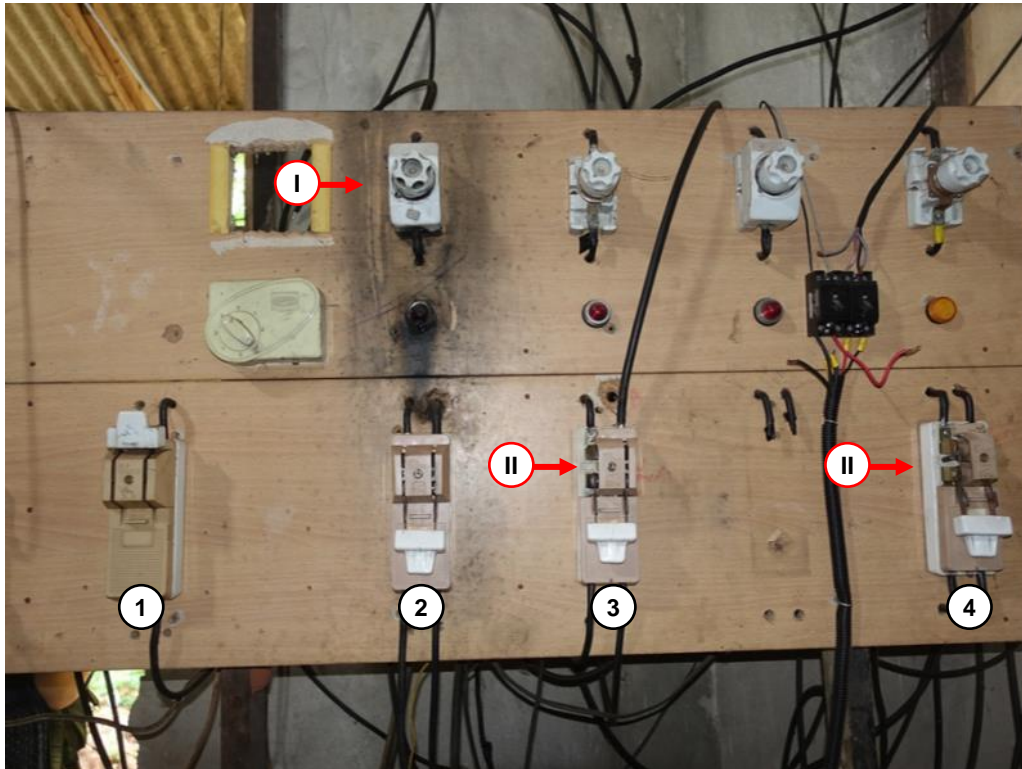

Figure 28: Switchgear for Generator #40 with four switches [1 – 4], four fuses [I] and partly open switch covers [II].

A general overview displaying the wiring schematic of Generator #40 and its grid is shown in the Single Line Diagram (SLD) below. It has to be noted that initially approx. 25 households had been connected per phase to the grid. However, around 25 households have been additionally connected to the existing grid in the years thereafter.

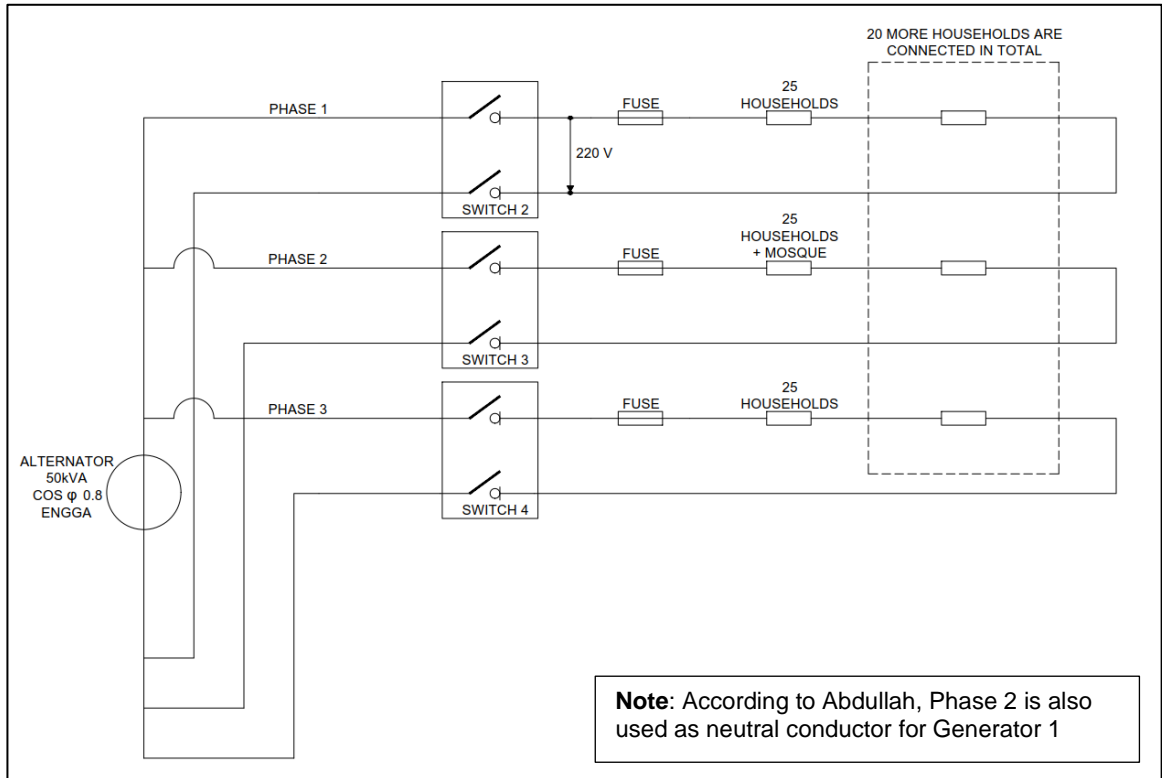

Figure 29: SLD of the Generator #40 System

#### 6.4 Grid Stability and Conditions

As described in Chapter 6.3, several important protection devices are missing. As a result, blackouts are occurring on the island. These are caused by some of the following reasons:

1. High load appliances such as use of electric irons (although not permitted)
2. Lightning strikes
3. Failure of generators
4. Damaged grid

To ensure a proper management, a new grid with all safety measures shall be considered.

#### 6.5 Grid Recommendations

A Hybrid system should come along with a new grid, connecting all houses. All cables and poles shall be replaced.

Figure 30 shows an overview over the island with the proposed transmission line route as black colour. The proposed transmission line may be aligned along the main road with the length of approx. 9.5 km. The transmission line shall be investigated to be either

single phase or three-phase system design. In addition, the figure shows the possible PV hybrid system locations as described in detail in Chapter 10 and 11.

Table 4 shows the specifications of a new installed grid to supply the island as recommended.



Figure 30: Proposed transmission lines on Koh Mak Noi

Table 4: Proposed setup of the new grid

Parameter	Value
<b>Cables</b>	
Total transmission route length [m]	Approx. 9.5 km
Cable cross section [mm <sup>2</sup> ]	To be specified and calculated
Insulation type	XLPE Insulated and PVC Sheathed Power Cable
Cable type	Weather Proof Conductor
Number of households connected to the hybrid system	To be specified
<b>Poles</b>	
Type	Wooden pole and/or concrete pole (optional)
Number of poles	To be specified
Height of poles [m]	Minimum 2.5 meters according to the Thai Standard
Etc.	Pole installation shall be in accordance with PEA standard
Optional	Direct burial underground cable in a minimum depth of 0.60 m according to

	Thai Electrical Code
--	----------------------

## 7 LOAD PROFILE AND ENERGY CONSUMPTION

No generator has a data logger. The load profile and energy consumption shall be analysed after the Consultant receives the measurement data.

### 7.1 Load Measurements

The Consultant installed two load measurement devices on Koh Mak Noi on 6<sup>th</sup> of March 2017 to measure the energy consumption of the connected generator loads till the 6<sup>th</sup> of April 2017. The devices measure relevant grid parameters like voltage; current, active and reactive power and frequency for each phase separately. They were installed in the following grids:

Table 5: Load measurement

Device	Connected to Generator	No. of phases	Number and type of connected houses
Koh Mak Noi 1	Generator #40	3	<ul style="list-style-type: none"> <li>• 101 residential houses inclu.                             <ul style="list-style-type: none"> <li>○ 5 combined households/ shops</li> <li>○ 3 combined households/ shops/ restaurants</li> <li>○ 1 combined household/ shop/ motorbike repair</li> <li>○ 1 health centre (not in use)</li> <li>○ 1 currently abandoned house</li> </ul> </li> </ul>
Koh Mak Noi 2	Generator #41	3	<ul style="list-style-type: none"> <li>• 71 residential houses inclu.                             <ul style="list-style-type: none"> <li>○ 4 combined households/shops</li> <li>○ 1 combined household/shop/motorbike repair</li> </ul> </li> </ul>

## 8 ELECTRICITY PRICE STRUCTURE

### 8.1 General

There is an existing electricity tariff structure, but it differs for each operator. The costs are allocated on a flat rate base, which is described in the following chapters. Since there are no meters installed, the electricity can be used unlimited during the operation hours of the generators.

Actual generation costs can hardly be assessed, because data recording, monitoring of actual consumption and the operation and maintenance costs are hardly tracked and recorded.

It is questionable if the price is monitored, and adjusted since the information available is not going to details.

## 8.2 Electricity

For Generator #40 and Generator #41 operated by Mr. Abdullah, the users reported to pay a flat rate per month based on their installed appliances, regardless of usage or efficiency. The consumers have been divided into 2 consumer groups, namely “Low Load Consumers” (only TV, light and fan’s) and “High Load Consumers” (TV, light, fan, washing machine and electrical iron).

Table 6: Pricing and loads of 2 consumer groups

Consumer	Price Per Month	Operation Hours	Typical Loads
Low Load	500	6 pm – 10 pm	Light and TV
High Load	600	6 pm – 10 pm	light, TV and washing machines, electrical iron

For users connected to Generator #68 (operated by Mr.Shade) and Generator #66 (operated by Mr.Weerachai) the users pay a flat rate of 500 THB and 600 THB per month, respectively. This is regardless of their installed appliances or amount of consumption.

The collection period for all of the operators are on the basis of a 15-day timeframe. The reason behind is that they are fishermen and more used to the lunar timeframe. It is also reported by the operator that chances of successful collection are higher within this timeframe.

It has to be noted that the community appreciated the idea of prepaid meters to control the consumption in the future.

With regard to the usage of high-power appliances (e.g. electrical iron), a fair solution shall be found. A prohibition of such appliances could lead to non-acceptance of the central hybrid system.

## 8.3 Diesel Cost

The diesel price consists of 2 parts: The actual diesel price and the transport of the diesel from the mainland.

The current price per litre diesel paid on the Island is **25 THB/l**. The price is linked to mainland diesel prices at gas stations.

The actual transportation costs are considered to be low. A roundtrip costs 300 THB and an estimated 1,500 l of diesel can be loaded on a long tail boat. Therefore, the delivery price per litre diesel is approximately 0.2 THB/l (or approximately 0.01% of the actual diesel price). However, this is only the case if the long tail boat is effectively used and fully loaded, otherwise the price per litre will increase.

Diesel consumption and cost for each generator, including transportation cost, is shown in table 7.

Table 7: Diesel consumption and cost

	Diesel Consumption (Litres)	Diesel Cost (THB)	Transportation Cost (THB)*	Total Cost (THB/Month)
Generator #40	1,050	26,250	300	29,250
Generator #41	750	18,750	300	19,050
Generator #66	330	8,250	300	8,550
Generator #68	540	14,580	-**	14,580

\* Assumed 1 trip per month

\*\*It has to be noted that Generator #68 is buying diesel from a supplier on the island (rate: 2 THB/l higher than onshore) and therefore does not bare any transportation cost.

#### 8.4 Maintenance Costs and Others

Maintenance for the generator – for instance for Generator #40 and #41 - is conducted every 45 days. Lubricant oil 18 l (1,500 THB), engine oil treatment (300 THB) and oil filter (150 THB) are replaced. The cost for each round of maintenance is 1,950 THB.

The total maintenance cost for these 2 Generators– is approx. **16,000 THB/year**.

Generator #66 and #68 are smaller and use less lubricant oil, it is estimated that these generators have a maintenance cost of approx. 9,600 THB/year.

#### 8.5 Summary of Costs and Income

##### Generation Costs

The total generation costs are calculated from diesel costs (incl. transport) and general maintenance of each generator.

Table 8: Total Generation Costs for each Generator

	Diesel Cost (THB)	Maintenance Cost (THB)	Total THB/Month
Generator #40	29,250	1,334	30,584
Generator #41	19,050	1,334	20,384
Generator #66	8,550	800	9,350
Generator #68	14,580	800	15,380

Generated income for each generator are calculated from the pricing structure of each generator and the No. of households (consumers) it supplies.

Generated income

Table 9: Generated Income for each Generator

		No. of consumers	Price	Total THB/Month
Generator #40	High load	15	600	9,000
	Low Load	85	500	42,500
	<b>Total</b>			<b>51,500</b>
Generator #41	High load	15	600	9,000
	Low Load	55	500	27,500
	<b>Total</b>			<b>36,500</b>
Generator #66		20	500	<b>10,000</b>
Generator #68		38	600	<b>22,800</b>

**8.6 Estimated Income**

Table 10: Income statement for each Generator

	Income	Cost	Net Income (THB)
Generator #40	51,500	29,250	22,250
Generator #41	36,500	19,050	17,450
Generator #66	10,000	8,550	1,450
Generator #68	22,800	15,380	7,420

It shall be noted that the load measurement will bring more insight into the actual electricity consumption on the island and therefore the price per kWh can be estimated more adequately.

## 9 FUTURE ENERGY CONSUMPTION

During the socio-economic survey, the future possible appliances have been assessed. These include rice cooker, refrigerator, washing machine, fan, blender, TV, power tools etc. Refrigerators are in highest demand for both household and local businesses. It has to be noted that most people were not keen on installing air conditioning devices. Electrical iron appliances have not been reported for the future appliances, however, some households nowadays secretly use the iron resulting in electricity black out and breaking other appliances connected to the same grid. Their usage shall be considered in the design of the PV hybrid system.

## 10 POSSIBLE AREA FOR POWERHOUSE

The island representatives did not provide a possible area for the installation of a new powerhouse, however the Consultant has figured out 2 suitable locations as shown in Figure 31. The powerhouse shall consist of diesel generators, diesel tanks, lubricant oil tanks, a battery system and a control/monitoring housing. The 2 sites are in the pond area and around the public health centre.

Both options do have individual pros and cons to be discussed, however, in a final selection it shall be considered to have the powerhouse and the PV area as close as possible. Moreover, it shall be ensured to keep a close distance to the existing houses to minimize the grid extension.



Figure 31: Two possible locations for new power house

Area 1: Abandoned building near to the pond

Around the pond, an existing small grid of approx. 300 m has been set up to connect the PV/Wind Hybrid System. It also supplies electricity to 5 bungalows via a generator. The grid uses the 25mm<sup>2</sup> THW-A for main transmission line.

However, this transmission line is currently not in operation because the generator in the abandoned building was removed. The grid condition is good. Wooden poles aligned from the abandoned building until the end of transmission can still support the cables as shown in Figure 32.

The access to the area is a concrete road of approx. 5 m width.



Figure 32: Wooden poles of an existing transmission line

At the end of the concrete road, there is an abandoned building which has an approx. size of 3m×4m as shown in Figure 33. A new power house for a hybrid system shall be in the vicinity of this area.



Figure 33: Possible area for new power house with the abandoned building

### Area 2: Health Centre

The health centre provides space, flat land and low flood risks and may therefore be considered as a good location for a power house. However, the noise impact around a health centre and the pier shall be critically weighted. The total area for the installation of a power house and a PV system is described in more detail in chapter 11.1.

## 11 POSSIBLE AREAS FOR PV INSTALLATION

Areas to install and implement a PV system have been identified and investigated. The results are provided in the following chapters. The final required area shall be determined after system design and the most suitable sites can be selected. Figure 34 shows the overview of possible 11 PV installation areas observed during the site visit.

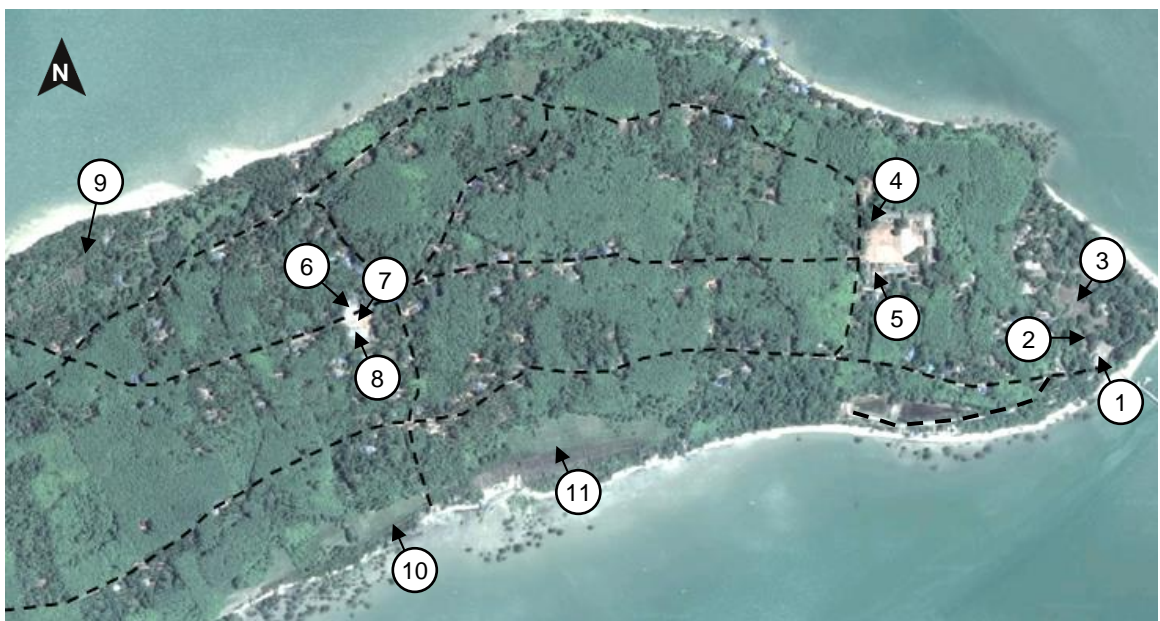

Figure 34: Overview of 11 possible PV installation areas

Table 11: Data summary of pre-selected and reviewed PV areas

Item	Area 1	Area 2	Area 3	Area 4	Area 5	Area 6
GPS coordinates of site	8°17'12.48"N 98°35'52.62"E	8°17'13.61"N 98°35'51.59"E	8°17'15.93"N 98°35'51.71"E	8°17'20.93"N 98°35'36.62"E	8°17'17.94"N 98°35'37.40"E	8°17'15.46"N 98°35'3.09"E
Land owner	Public health centre		Police	School		Mosque
Area borders	1) 8°17'14.00"N 98°35'52.13"E 2) 8°17'14.43"N 98°35'51.50"E 3) 8°17'13.20"N 98°35'51.23"E 4) 8°17'12.78"N 98°35'51.47"E	It was not possible to clarify the exact area boundary as there are no land titles / documentation available at this stage.				
Size of area	~500 m <sup>2</sup>	~700 m <sup>2</sup>	~7,000 m <sup>2</sup>	~300 m <sup>2</sup>	~200 m <sup>2</sup>	~200 m <sup>2</sup>
Distance to next grid connection	~150 m (grid of Generator #66)	~200 m (grid of Generator #66)	~250 m (grid of Generator #66)	~100 m (grid of Generator #68)	~200 m (grid of Generator #68)	~20 m (grid of Generator #40)
GPS coordinates for grid connection	It cannot be surely clarified since the possible power house/generation location of a hybrid systems needs to be determined					
Size of grid connection point	Existing grid line is 220 V / Based on the Hybrid System Design					
Distance to power house	To be determined					
Slope	~0°	~0°	~0°	~10°-15° E/W	~0°	~10°-15° N/S
Necessity to clear the site	Yes, the existing installed PV	Yes	Yes	No	No	No
Visible soil conditions	sandy to clay with observed smaller boulders			Rooftop	Clay	Rooftop
Temporary flooding risks	Low	Low	Low	Not observed	Not observed	Not observed
Preferred areas by ILF	Preferred area		<b>To be discussed with SAO, community and police</b>	Not selected area since to the school is not willing to export any electricity to the public.		Selection shall be considered by community. Religious sites are usually and preferably spared out.

Item	Area 7	Area 8	Area 9	Area 10	Area 11
GPS coordinates of site	8°17'14.66"N 98°35'3.60"E	8°17'14.01"N 98°35'3.07"E	8°17'17.81"N 98°34'44.81"E	8°17'1.16"N 98°35'3.65"E	8°17'7.09"N 98°35'17.23"E
Land owner	Mosque		Mr. Abdullah	Businessman	
Area borders	1) 8°17'15.16"N 98°35'4.38"E 2) 8°17'14.07"N 98°35'4.33"E 3) 8°17'14.29"N 98°35'2.70"E 4) 8°17'14.64"N 98°35'2.66"E	It's not necessary because of the building (not an open-field area)	1) 8°17'17.52"N 98°34'45.71"E 2) 8°17'18.42"N 98°34'45.43"E 3) 8°17'18.00"N 98°34'44.02"E 4) 8°17'17.10"N 98°34'44.43"E	It was not possible to clarify the exact area boundary	
Size of area	~900 m <sup>2</sup>	~500 m <sup>2</sup>	~1,300 m <sup>2</sup>	~10,000 m <sup>2</sup>	~17,000 m <sup>2</sup>
Distance to next grid connection	~40 m (grid of Generator #40)	~50 m (grid of Generator #40)	~200 m (grid of Generator #41)	~300 m (grid of Generator #40)	~150 m (grid of Generator #40)
GPS coordinates for grid connection	It cannot be surely clarified since the possible power house /generation location of a hybrid systems needs to be determined				
Size of grid connection point	Existing grid line is 220 V / Based on the Hybrid System Design				
Distance to power house	To be determined				
Slope	~0°	~10°-15° N/S	~0°	Upper part: <5° (South-East direction) Lower part: ~0°	N/A
Necessity to clear the site	No	No	Yes	Yes	Yes
Visible soil conditions	Sandy to clay	Rooftop	Clay	Clay	Clay
Temporary flooding risks	Not observed	Not observed	Low	High	High
Preferred areas by ILF	Selection shall be considered by community. Religious sites are usually and preferably spared out.		<b>To be discussed</b>	<b>To be discussed</b>	<b>To be discussed</b>

### 11.1 Area 1-3: Public Health Centre

The public health centre has an open-field area which can be utilized as shown in Figure 35. The size of the Area 1 is approximately 500m<sup>2</sup> on flat and levelled terrain. If a PV system is planned, the removal of the existing system shall be considered, which is currently facing South (azimuth 0°). Shading analysis shall be conducted due to surrounding trees and the houses to the West.

The soil is mainly sandy to clay with observed smaller boulders. The area seems to have a low flood risk, nevertheless a minor drainage system to ensure rainwater draining off should be considered.



Figure 35: Possible area to install new a PV system at public health centre (Area 1)

The surrounding of the health centre shows two more possible areas behind the centre (Figure 36):

- Area 2 is owned by the public health centre; it can be utilized for a new PV system. The size of the area is approx. 700 m<sup>2</sup>.
- Area 3 is owned by the police and may also be considered to install a new PV system. According to information from Mr. Abdullah, the area has not been used since a very long time. This opportunity can be discussed with the owner and the SAO. The size of the area is approx. 7,000 m<sup>2</sup>.

Both areas are quite flat. The next existing grid would be the same as for Area 1. The soil condition is mainly clay. The areas seem to have a low flood risk, a minor drainage system shall however be considered. A shading analysis shall be conducted due to surrounding trees. Moreover, the trees within the boundaries can be cut if necessary.



Figure 36: Two possible areas behind public health centre (Area 2-3)

As seen in Figure 19, the next existing grid would be the grid from Generator #66 (Mr. Weerachai) with a distance of approximately 150 m to the health centre. Additionally, the non-connected grid starting at the generator around the wind turbines is located around 200 m away from the health centre (see Chapter 10).

## 11.2 Area 4-5: School Area

There are two possible areas to install a PV system. On the one hand the roof of the newly built school (Area 4) and on the other hand the replacement of the existing PV system (Area 5).

Figure 37 shows the roof of the new school building which has approx. 300 m<sup>2</sup> (12 m x 25 m) with 7 m height. The roof is facing East-West with an inclination of 10-15°. There is a possible shading caused by the coconut trees in the Western side of the building.

Figure 38 shows the existing PV area supplying the electricity for the school with an approx. size of 200 m<sup>2</sup> (10m x 20m). Possible shading from the small building in the South shall be avoided.

According to Figure 19, the next existing grid is the one originating from Generator #68 (Mr. Shade) with a distance of approx. 200 m. Both areas seem to have a low flood risk.

Although showing interest in receiving more electricity, it has to be noted that the school's director did not show interest in exporting power to the public if a system is being installed on the school's premises. Therefore, such a system could only supply the school itself, thus the area shall not be considered unless no other options can be identified.



Figure 37: Roof overview and structure of new school building (Area 4)



Figure 38: Existing PV area at school (Area 5)

### 11.3 Area 6-8: Mosque Area

Figure 39 shows three possible PV installation areas which are the roof of the religion learning building, an open-field area in front and on top of the roof of the mosque. The mosque has a road access with a width of around 3.5 m. As shown in Figure 19, the area is very close to the grid from Generator #40 (Mr. Abdullah).

The open-field area has an approx. size of 900 m<sup>2</sup>. There is possible shading not only from surrounding trees with approx. 5 m to 10 m height but also from the mosque building itself.

It has to be noted, that utilization of the area requires approval by the SAO. The mosque area might be considered as inappropriate to install PV systems for the religious character of the building. This needs to be assessed.



Figure 39: Overview of mosque area (Area 6-8)

Figure 40 shows the roof structure of the religion learning building which would be able to withstand a PV rooftop installation. The size of the roof is approx. 200 m<sup>2</sup> (10m x 20m) with 3 m height. The roof is facing towards North-South with an approximate inclination of 10-15°.



Figure 40: Roof structure and roof sheet of religion learning building (Area 6)

Figure 41 shows the mosque roof. The size of the roof is approximately 500 m<sup>2</sup> (25m x 20m) with 6 m height. The roof is a hip roof which has slopes on all four sides with an approximate inclination of 10-15°.



Figure 41: Mosque roof (Area 8)

#### 11.4 Area 9: Mr. Abdullah's Area

Figure 42 shows the area owned by Mr. Abdullah, which may be considered to install a PV system. The area has an approx. size of 1,000 m<sup>2</sup>, and is in a distance of 100 m to the beach. According to Figure 19, the next existing grid would be the grid arising from Generator #41 (Mr. Abdullah) with a distance of approx. 200 m. There is a dirt road access to the area. The area is quite flat; however, it is lower than the main road. Loose, wet soil and small water ponding was observed as shown in Figure 43. Drainage requirements shall be investigated. The trees within the boundaries could be cut – if necessary.

It has to be noted that a lease agreement with Mr. Abdullah would be needed to use the area.



Figure 42: Overview of Abdullah's area (Area 9)



Figure 43: Soil condition of Abdullah's area (Area 9) and small pond

### 11.5 Area 10-11: Open-Field Area Closed to Seashore

Figure 44 shows two large areas in close proximity to the sea, owned by a private businessman. The risk of flooding may be high. During the site visit, most of the area was occupied by ponding water. According to Figure 19, the closest grid would be the grid from Generator #40 (Mr. Abdullah) with a distance of approx. 300 m and 150 m for Area 10 and Area 11, respectively. The size of the Area 10 and Area 11 is approx. 10,000 m<sup>2</sup> and 17,000 m<sup>2</sup>, respectively.

It has to be noted that using these areas might also require a leasing agreement, similar to Area 9, which shall be clarified with the SAO.

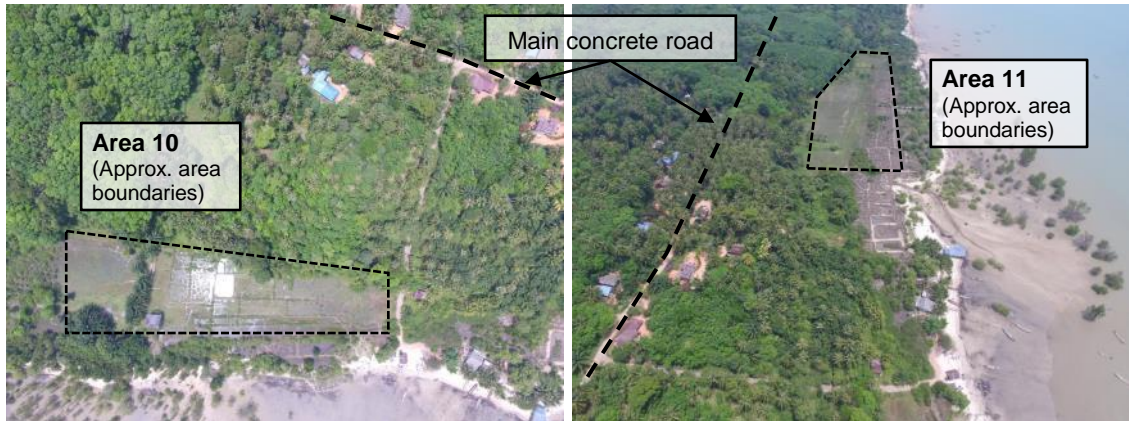

Figure 44: Open-field area (Area 10-11)

## 12 WATER STORAGE SYSTEM

Figure 45 shows the island's water storage system. It comprises of two large ponds collecting rain water. Three pumps are used to pump the water from the ponds into a water tower. Two pumps are driven by a diesel generator and one pump is supplied by the PV-wind-battery hybrid system which is currently out of order. Therefore, the PV-wind hybrid system is currently used to charge the batteries only.

There is another pump below the water tower to distribute the water to each household. All equipment of the water storage system is operated and maintained by Mr. Abdullah. It has to be noted that the island is experiencing water shortage from time to time.

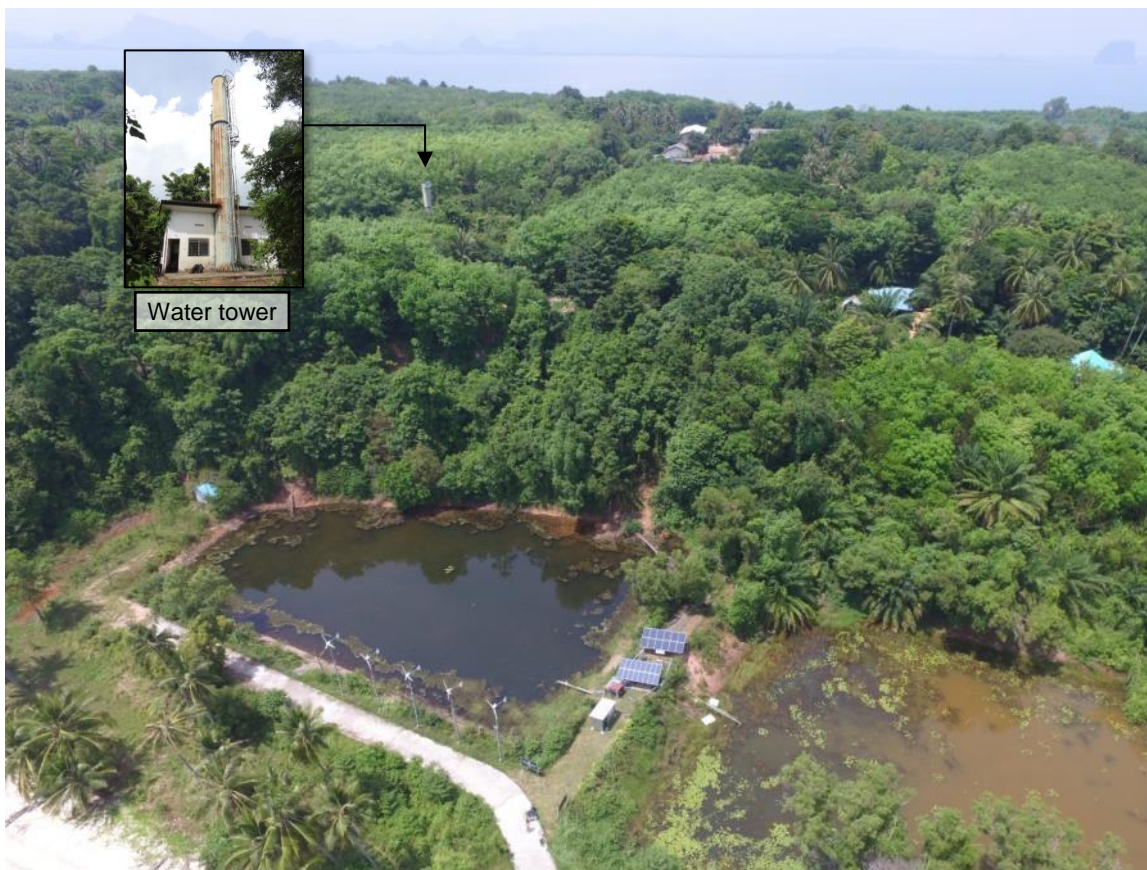

Figure 45: Water storage system with two large ponds

### 13 LOGISTICS AND INFRASTRUCTURE

#### 13.1 Transportation on the Island

The transport on Koh Mak Noi relies heavily on motorbikes with and without sidecar as shown in Figure 46. For transport of heavy gear there is a pick-up truck on the island which might be suitable (see Figure 48).



Figure 46: Motorbikes with- and without sidecar.

### 13.2 Construction and construction vehicles

On Koh Mak Noi some vehicles for construction purpose exist. An excavator, a pick-up truck and a manual concrete mixer for instance is currently in use at the school's premises to construct the new building. No cranes or other heavy construction equipment has been observed on the island.



Figure 47: Excavator and manual concrete mixer



Figure 48: Pick-up for excavated material

The labourers working on the school construction site were coming from the mainland. Building material, such as wood and sand, is mostly shipped from the mainland.

### 13.3 Trained manpower

There is an electrical technician with basic skills living on the island. He has also undergone a PV and hybrid training. Local motorbike repair shops have been observed on the island.

### 13.4 Possible laydown area and accommodation facilities during execution

Depending on the location of the new powerhouse and PV plant area, the decision will be made for the laydown area and accommodation for workers. There is sufficient space available. Furthermore, the public buildings such as mosque area, school area, etc. can be considered.

### 13.5 Roads

The roads on Koh Mak Noi are made of concrete and are in good condition. The width of the road is approx. 3 m - 3.5 m. The overview of the main concrete road on the island is shown in Figure 2.



Figure 49: Typical road on Koh Mak Noi

### 13.6 Pier

#### Mainland Pier

The closest pier to Koh Mak Noi is in Laem Sak, from where the island can be reached with the local long tail boat within approx. 20 min. The pier should be sufficient for the shipment of the gear. Depending on the weight of the gear it might be helpful to ship only during high tide as the water level at the pier seems to be low during low tide.



Figure 50: Laem Sak pier at low tide

### Island Pier

The pier of Koh Mak Noi is located in the very east of the island and may be sufficient for the shipment of the components (20 ft. container could be possible). The edge of the pier is always a minimum of 2 m above sea level independent of the tide. In the past, there was a huge flat boat conveying a pile of sand, 10-wheel truck, 6-wheel truck and excavator to the island. Another example of transportation for heavy equipment is Mr. Abdullah's generator and the tripod winches to lift the generator from the boat.

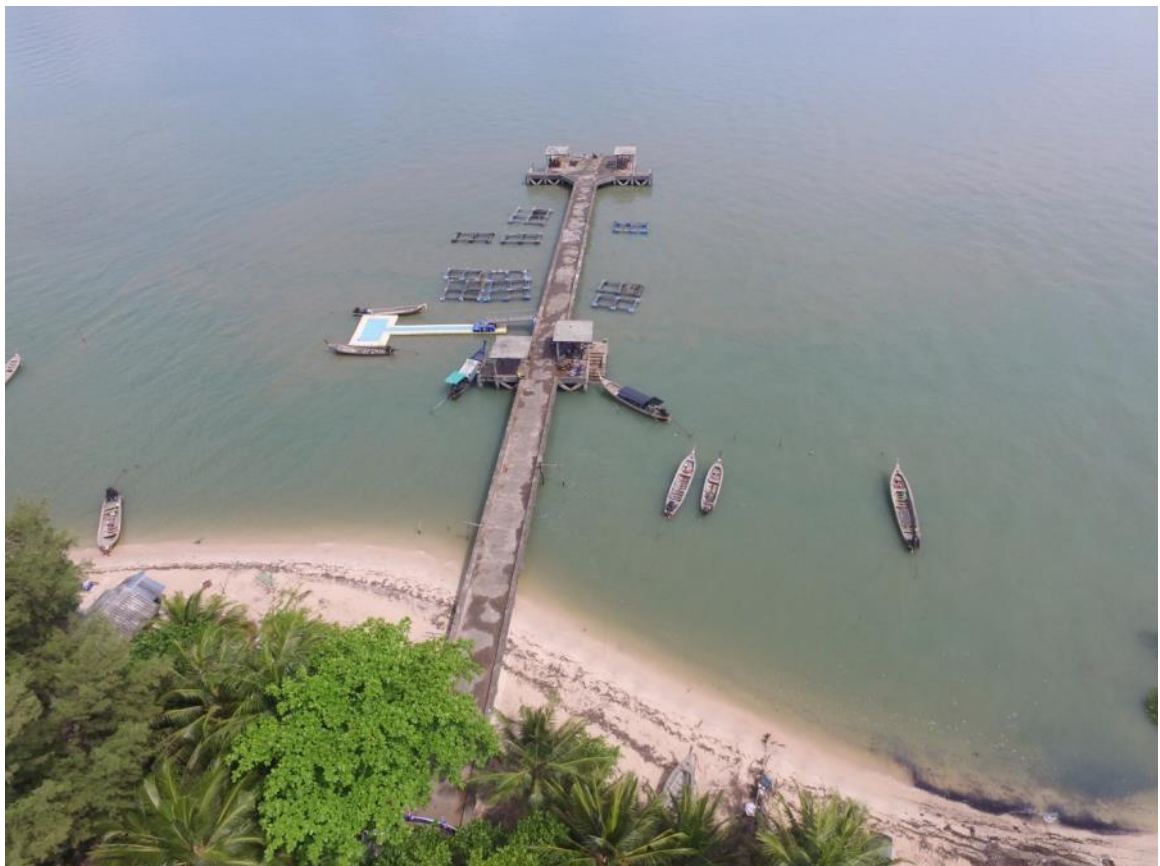



Figure 51: Koh Mak Noi pier

### 13.7 Fuel transport to the island

On Koh Mak Noi, some local shops are selling gasoline for motorbikes, as shown in Figure 52. However, diesel and gasoline is transported by long tail boat from Laem Sak pier.



Figure 52: Gasoline for sell observed on the island

## 14 FUTURE PLANS FOR SUBMARINE CABLE CONNECTION

During the community meeting, the chief of SAO reported that there are plans to connect the island with the national grid via submarine cable by PEA. The timeframe was not clear. GIZ checked with the responsible department in PEA and was informed that cable connection to Mak Noi island is not yet in the next 5-year grid extension plan of PEA (2016-2021). PEA plans to put it in the grid extension plan of years 2021-2026. In this case, the project will have to go through the following steps: 1) Investment feasibility assessment by PEA 2) Submit for cabinet approval 3) Allocation of budgets 4) Conduct EIA/EHIA studies 5) Procurement and construction. It will be a long process, which is expected to take more than 5 years from step 1-5. With regard to this information,

opportunities to implement the hybrid grid still stands, with possibilities of PEA to be a stakeholder in the hybrid grid project as well.

## 15 APPENDICES

Appendix 1: List of the generators observed during the site visit with GPS location

No.	Reference No.	GPS	No.	Reference No.	GPS
1	#40	8.28772, 98.58409	28	#67	8.2872, 98.59789
2	#41	8.28604, 98.57918	29	#68	8.2913, 98.59301
3	#42	8.28744, 98.58163	30	#69	8.29127, 98.59296
4	#43	8.28708, 98.58073	31	#70	8.2865, 98.59363
5	#44	8.28504, 98.58133	32	#71	8.28636, 98.59781
6	#45	8.28598, 98.58141	33	#72	8.28818, 98.58708
7	#46	8.28646, 98.58033	34	#73	8.28783, 98.59459
8	#47	8.28573, 98.58467	35	#74	8.28785, 98.59358
9	#48	8.28633, 98.58337	36	#75	8.28765, 98.5852
10	#49	8.28578, 98.58247	37	#76	8.28828, 98.58751
11	#50	8.28823, 98.58458	38	#77	8.28821, 98.58832
12	#51	8.28872, 98.58401	39	#78	8.28678, 98.5772
13	#52	8.28841, 98.58435	40	#79	8.28731, 98.57732
14	#53	8.28849, 98.58374	41	#80	8.2869, 98.57961
15	#54	8.28977, 98.58329	42	#81	8.28842, 98.59014
16	#55	8.28924, 98.58372	43	#82	8.2883, 98.57998
17	#56	8.28784, 98.58411	44	#83	8.28663, 98.59529
18	#57	8.29053, 98.58344	45	#84	8.28654, 98.59505
19	#58	8.29036, 98.58303	46	#85	8.28664, 98.59475
20	#59	8.28849, 98.58233	47	#86	8.28692, 98.59441
21	#60	8.2891, 98.58054	48	#87	8.28661, 98.59368
22	#61	8.28866, 98.5798	49	#88	8.28848, 98.58415
23	#62	8.28206, 98.5751	50	#89	8.29113, 98.59086
24	#63	8.28764, 98.58408	51	#90	8.29233, 98.59062
25	#64	8.28756, 98.58407	52	#91	8.28937, 98.58222
26	#65	8.28682, 98.5833	53	#92	8.28837, 98.59381
27	#66	8.2873, 98.59631			

Appendix 2: Generator information observed during the site visit

Reference No.	#40	#41	#62	#68	#66
<b>Generator</b>					
Owner/Operator	Mr. Abdullah	Mr. Abdullah	Mr. Usop	Mr. Shade	Mr. Weerachai
Continuous Power [kW]	40	40 (no nameplate, number according to oral information from Mr. Abdullah)	3 (no nameplate, number according to oral information from Mr. Usop's sister)	15	15
Power Factor	0.8	Unknown	Unknown	0.8	1.0
Number of phases	3	3	1	3	3
Frequency [Hz]	50	Unknown	Unknown	50	50 and 60
Fuel	Diesel	Diesel	Diesel	Diesel	Diesel
Operating hours	6 pm – 10 pm	6 pm – 10 pm	6 pm – 10 pm	6 pm – 10 pm	6 pm – 10 pm
Age	Since DEC 2014	Unknown	Unknown	Unknown	Unknown
<b>Grid</b>					
No. of connected households	Approx. 100	Approx. 70	8	38	Approx. 20
Cables	<ul style="list-style-type: none"> <li>10, 16 and 25 mm<sup>2</sup>, THW – A, 2541 Thai standard year</li> <li>Subsequently grid extensions: 2x2.5 mm<sup>2</sup>, VAF, 2553 Thai standard year</li> </ul>	<ul style="list-style-type: none"> <li>25 mm<sup>2</sup>, THW – A, 2541 Thai standard year</li> <li>Subsequently grid extensions: 2x2.5 mm<sup>2</sup>, VAF, 2553 Thai standard year</li> </ul>	2 x 1.5 mm <sup>2</sup> , VAF, 2531 Thai standard year	16 mm <sup>2</sup> , THW – A, 2541 Thai standard year	<ul style="list-style-type: none"> <li>10 mm<sup>2</sup>, THW – A, 2541 Thai standard year,</li> <li>2 x 2.5 mm<sup>2</sup>, VAF, 2553 Thai standard year</li> </ul>
Poles	Trees, wooden poles, old PVC water pipes	Trees, wooden poles, old PVC water pipes	Either cable lies directly on the ground or trees are used as poles	Cable is attached to palm trees	Cable is either attached to palm trees, concrete pillars or lying on the ground
Condition of the cables	Frequently fixed, should be replaced in case of a renovation	Frequently fixed, should be replaced in case of a renovation	Should be replaced in case of a new grid (too thin)	Good condition, some may be used further	Frequently fixed, should be replaced in case of a renovation
Age	3 years	3 years	Unknown	Unknown	Unknown

Appendix 3: Summary of PV Systems

	SHS	Health centre	BTS		School	Lake
<b>PV Module</b>						
Brand	Solartron	Solartron	Canadian Solar	SHARP	Uni-Solar	Solartron
Model	SP120	SP125	CS6X-300P	ND-130T1J	US-64	SP130E
Max power	120 W	125 W	300 W	130 W	64 W	130 W
Voltage max power	17.28 V	17.3 V	36.1 V	17.4 V	16.5 V	16.90 V
Current max power	7.0 A	7.23 A	8.3 A	7.48 A	3.88 A	7.70 A
Open Circuit Voltage	21.7 V	21.1 V	44.6 V	22.0 V	23.8 V	22.0 V
Short Circuit Current	7.45 A	8.02 A	8.87 A	8.09 A	4.8 A	8.20 A
Facing (Azimuth)	Various	210°	180°	180°	150°	South
Inclination	Various	20°	20°	20°	20°	N/A
<b>Battery</b>						
Brand	N/A	3K	N/A	N/A	Union	Yuasa
Model	N/A	EB160T	N/A	N/A	8 OPzS 800	EB130
Voltage	12 V	12 V	N/A	N/A	2 V	12 V
AH	100 AH	160 AH	N/A	N/A	800 AH	130 AH
Notes						

Appendix 4 – Site Survey Overview

See separate document: “3\_Mak Noi\_Survey Evaluation\_final”